

R. Douglas Style Guide

11/7/18

JACKET

0011 Single Breasted
One Button

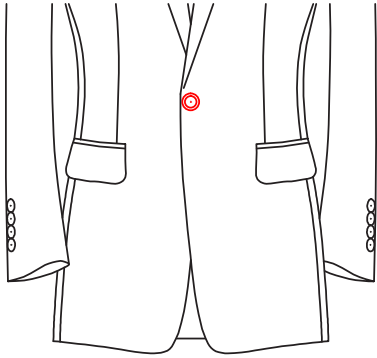

0012 Single Breasted
Two Button

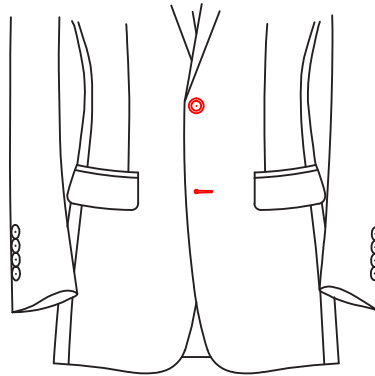

0013 Single Breasted
Three Button

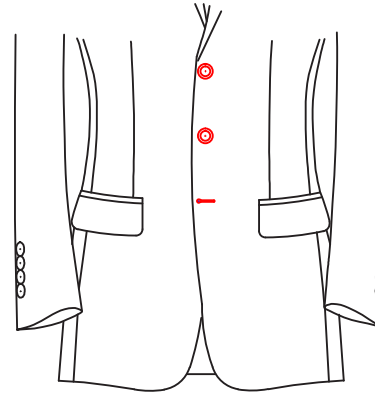

002B Single Breasted
Three to Two Button

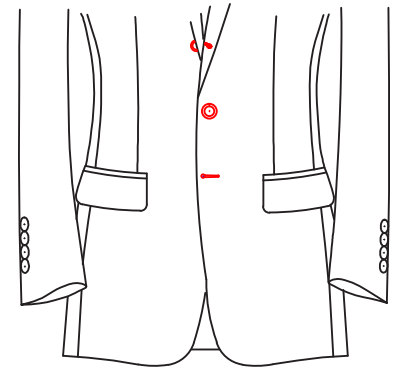

0017 Double Breasted
Four Button One Fasten

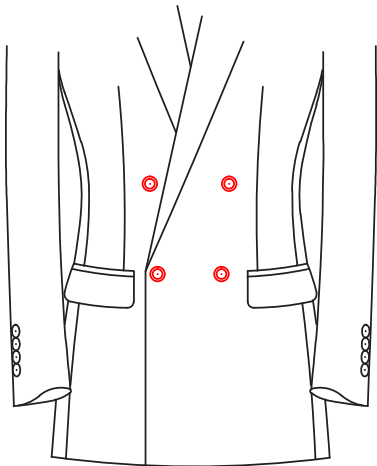

0015 Double Breasted
Four Button Two Fasten

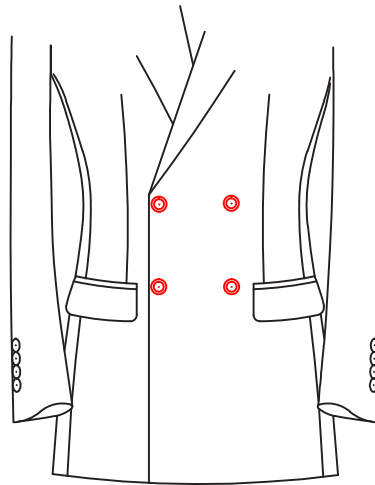

0018 Double Breasted
Six Button One Fasten

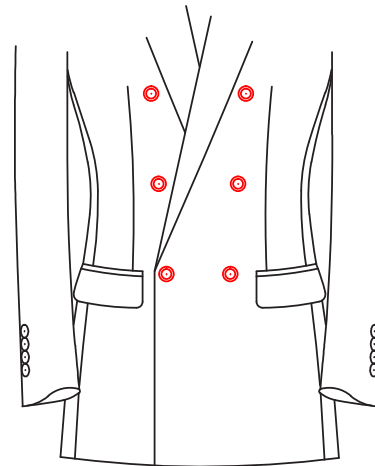

0016 Double Breasted
Six Button Two Fasten

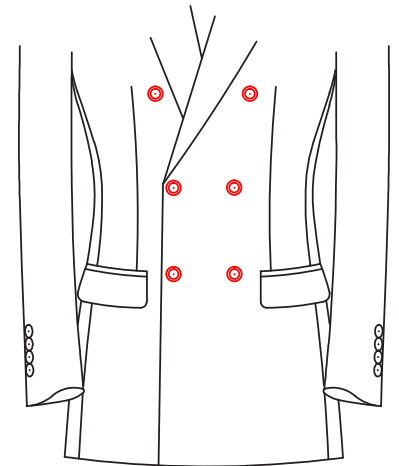

0001 Notch Lapel

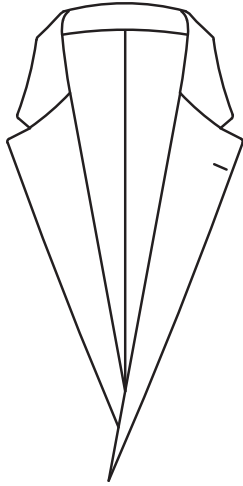

0002 Peak Lapel

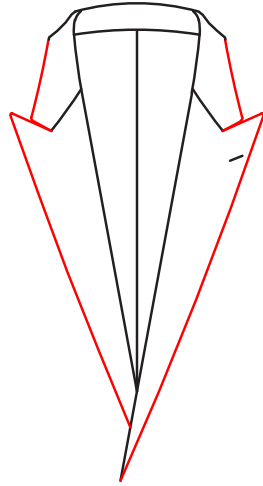

0005 Shawl Lapel

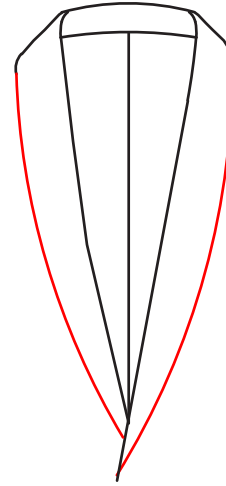

090A Shawl Lapel Half Arc

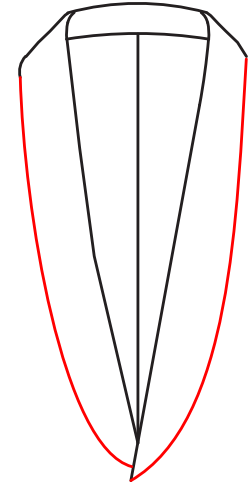

00F2 Shawl Lapel Full Arc

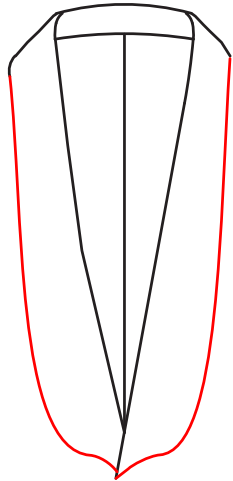

0541

Left Buttonhole

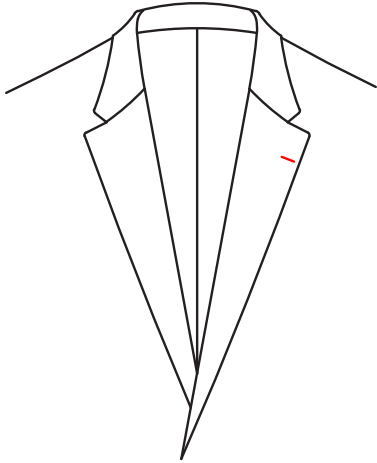

0542

Right Buttonhole

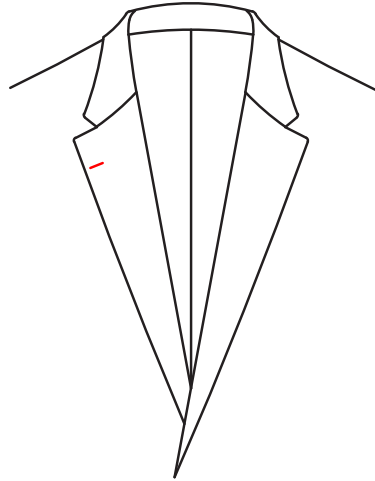

0543

Left & Right Buttonholes

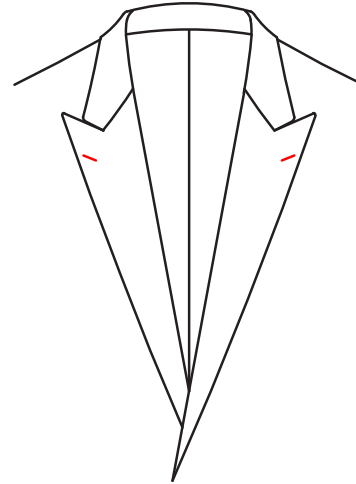

0544

No Buttonhole

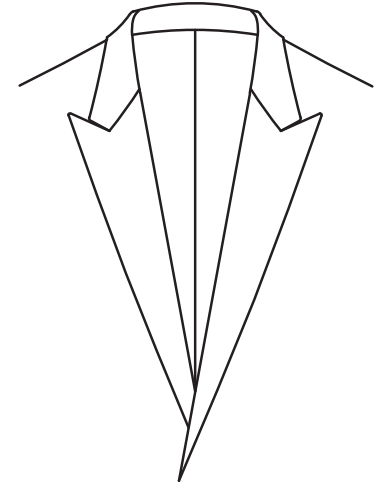

0545

Two Left Buttonholes

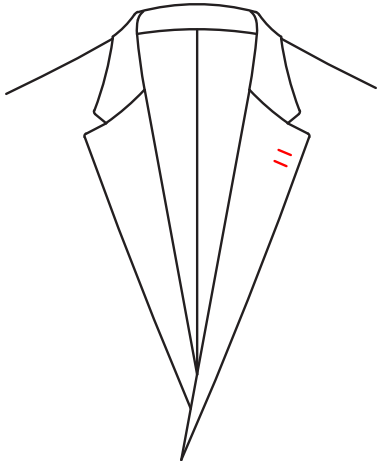

055P

Snawl Lapel Left Buttonhole

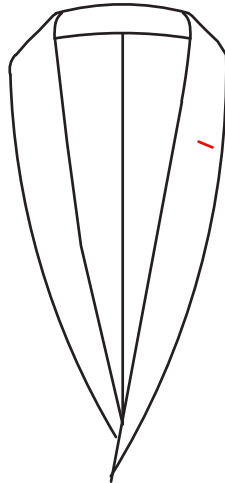

0201

Flap

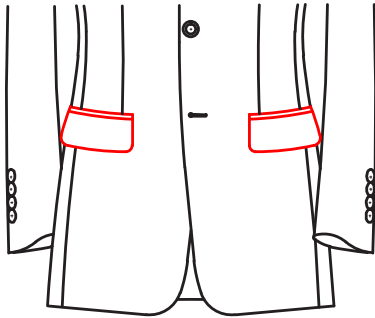

0202

Flap w/
Flap Ticket

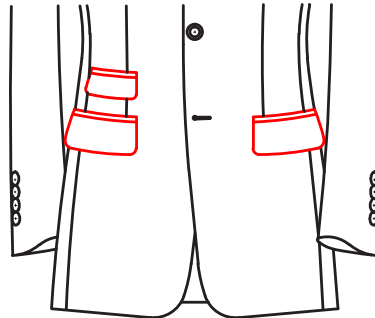

0231

Double Besom

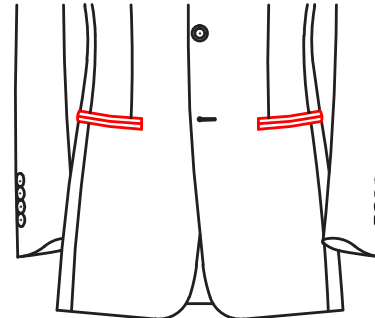

0234

Double Besom w/
Double Besom Ticket

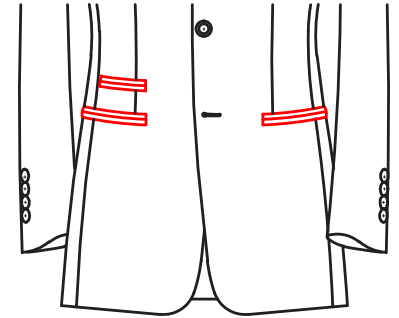

02A1

Slanted Flap

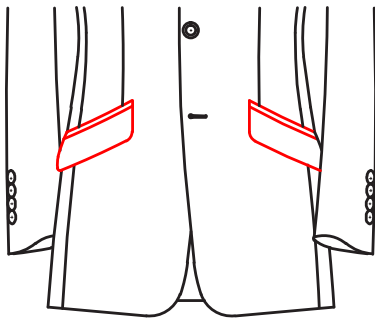

02A2

Slanted Flap w/
Flap Ticket

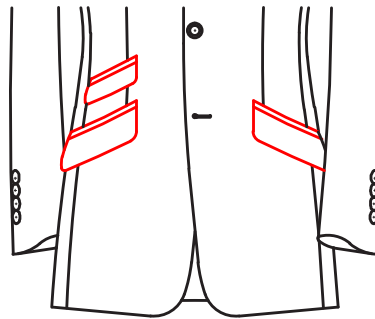

02D1

Slanted Double Besom

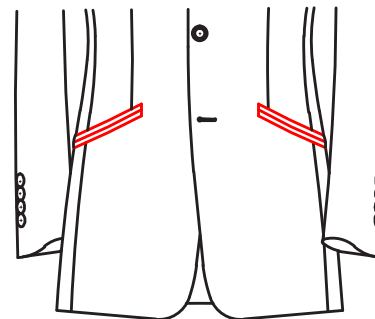

02D3

Slanted Double Besom w/
Double Besom Ticket

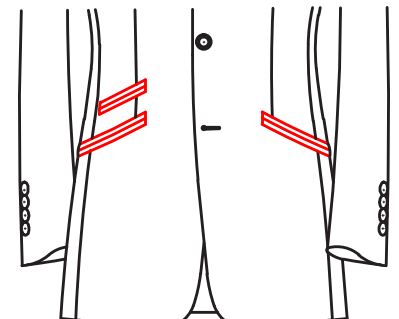

0204 Flap w/
Double Besom Ticket

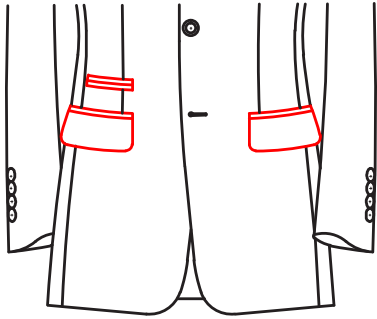

02J1 Patch

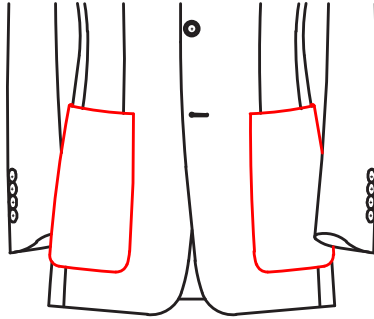

06K0 Patch w/
Patch Ticket

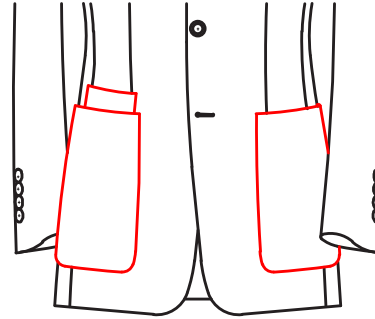

02L2 Patch w/ Flaps

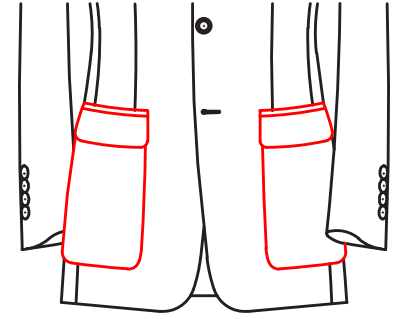

02A3 Slanted Flap w/
Double Besom Ticket

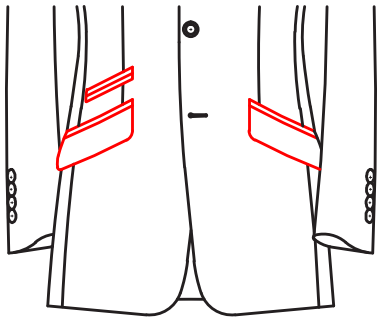

0625

Three Overlapping

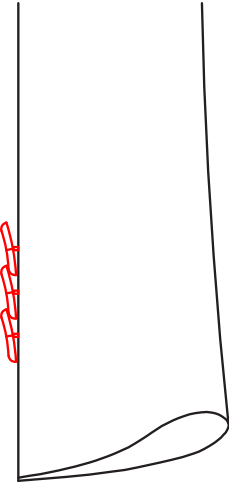

0624

Three Flat

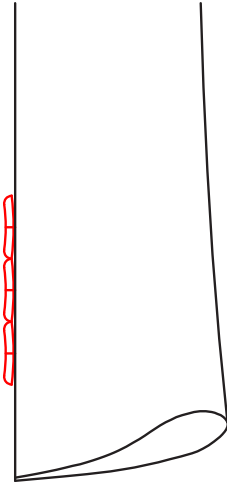

0622

Four Overlapping

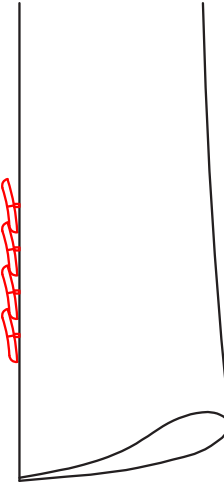

0621

Four Flat

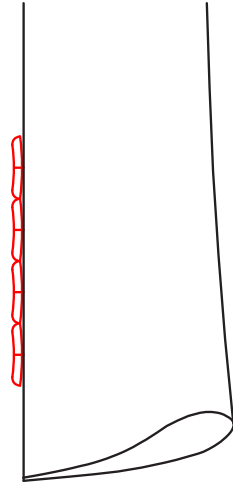

0628

Five Overlapping

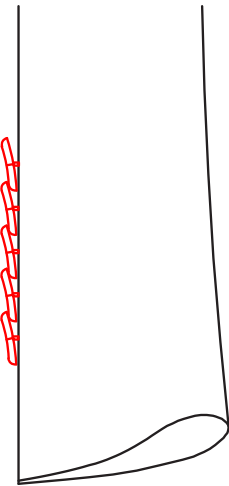

0627

Five Flat

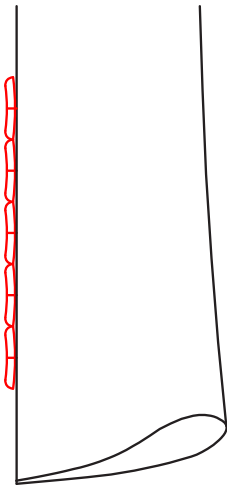

0612

Real Slit

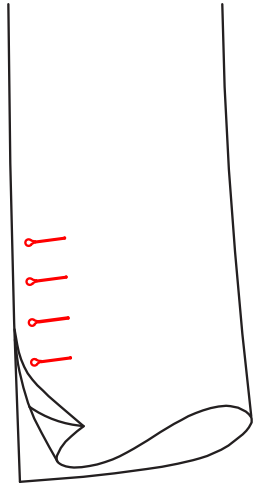

061D

Slanted Real Slit

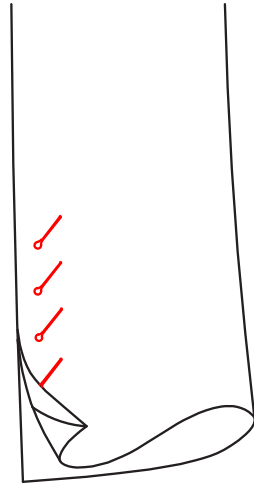

0571

narrow (0.15cm) Pick Stitch

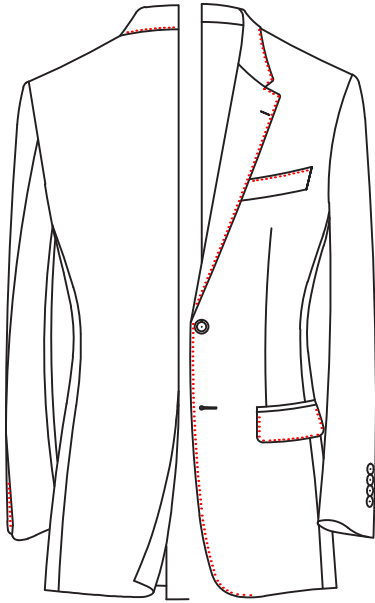

0577

wide (0.6cm) Pick Stitch

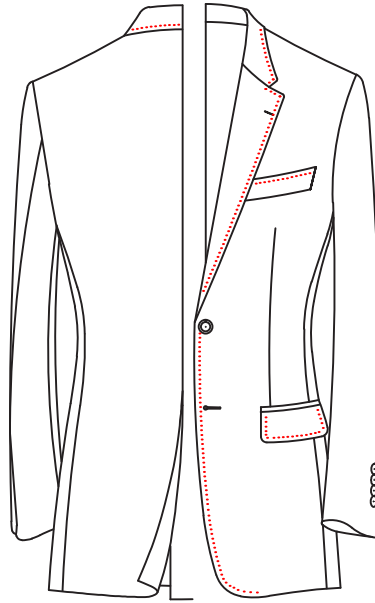

0570

No Pick Stitch

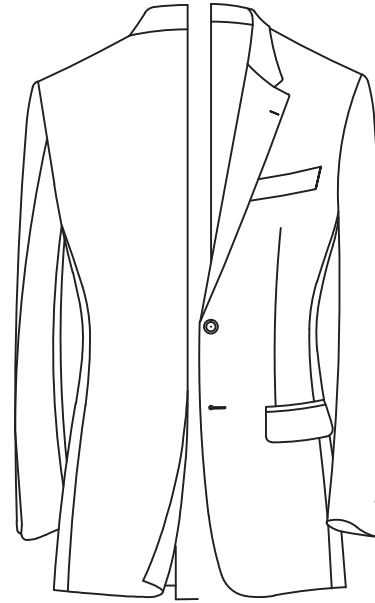

04N2

Side Vents

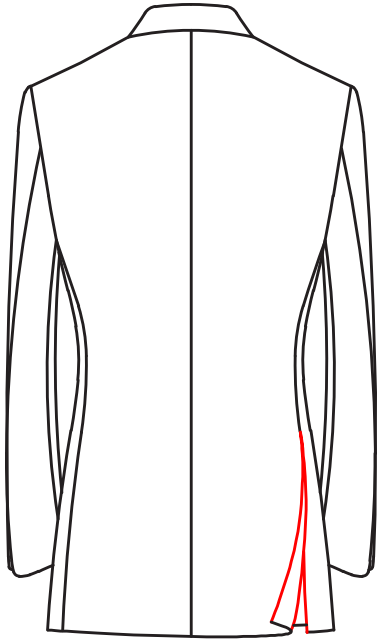

04N1

Center Vent

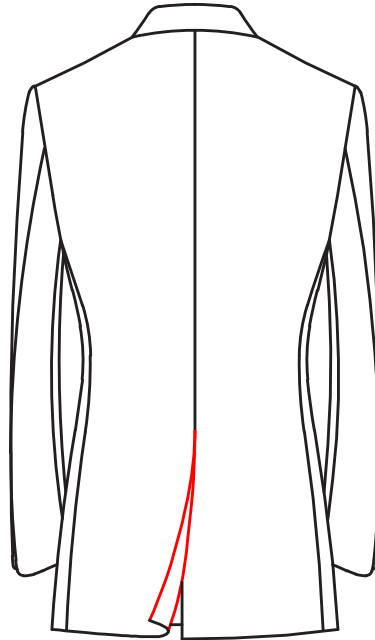

04N3

Side Vents w/ Strap

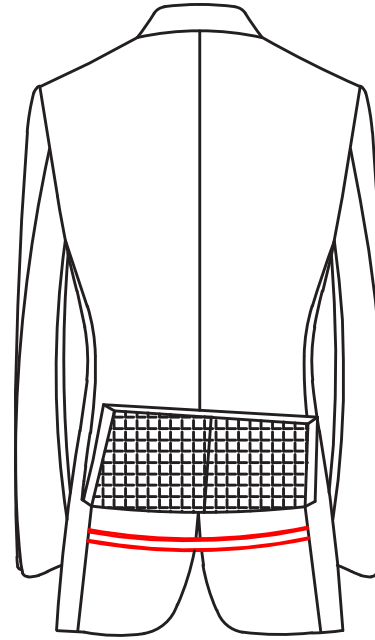

04N0

No Vents

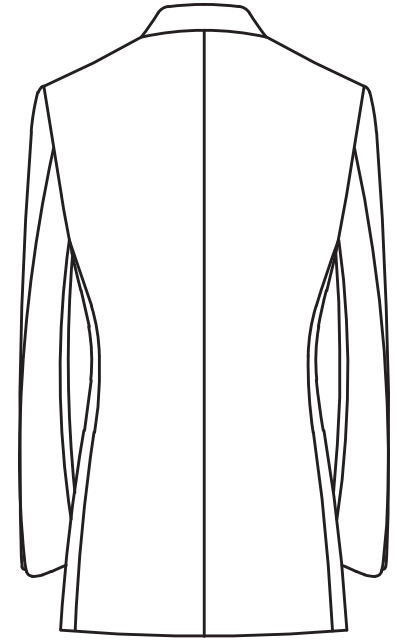

0601 Normal

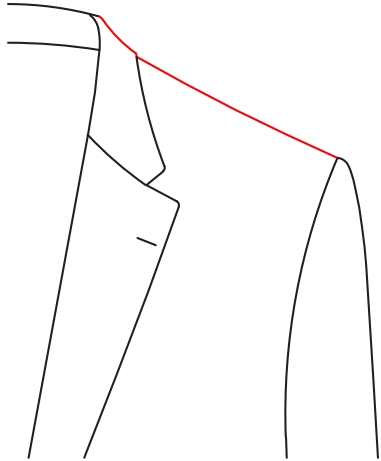

0603 Natural

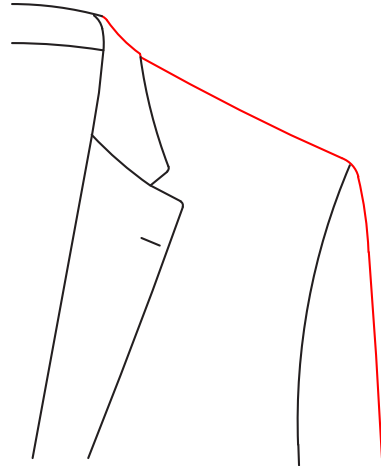

0604 Casual (Brunello Cucinelli)

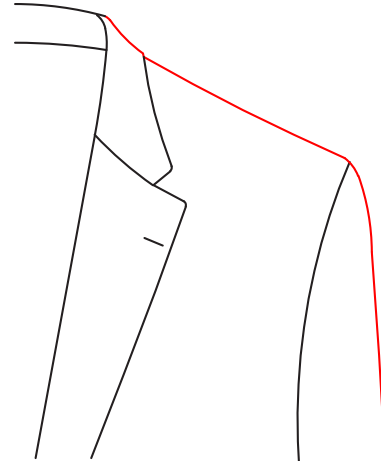

060A High Sleeve Head

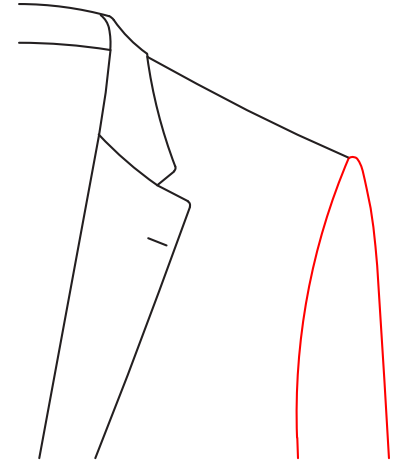

060N Neapolitan

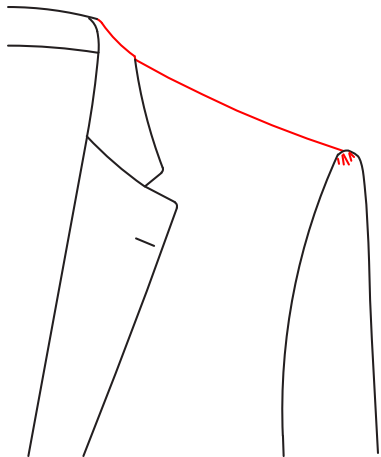

065C

Satin Buttons

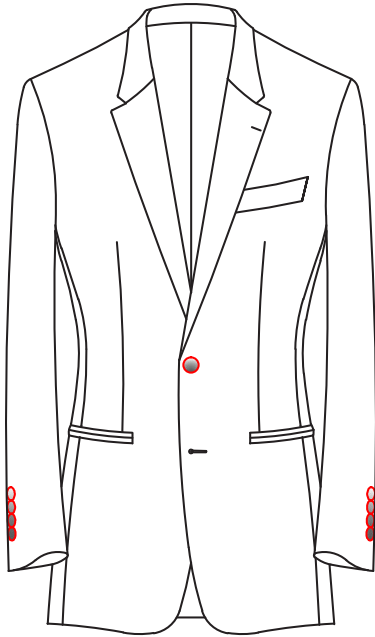

0664

Satin Double Besom Pockets

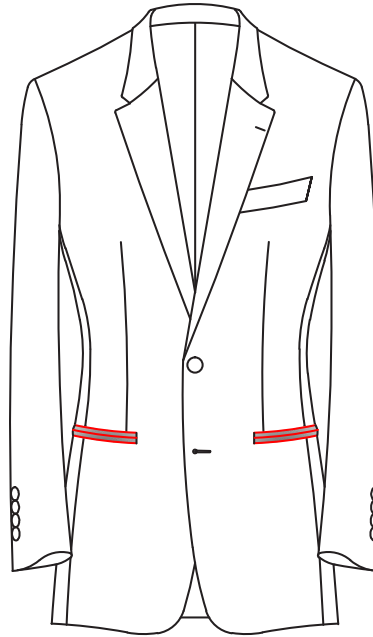

0652

Satin Lapel

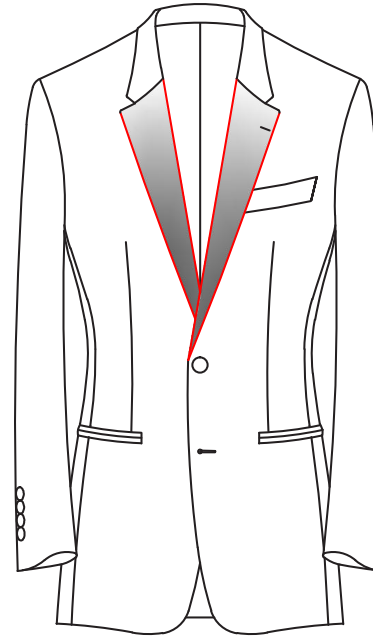

0651

Satin Top Collar

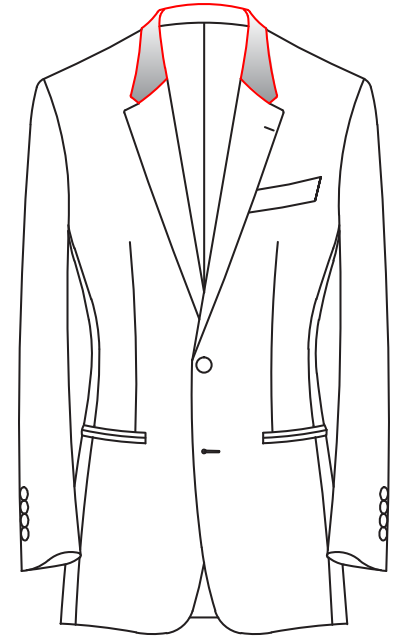

05C1 Round Bottom
Full Lining

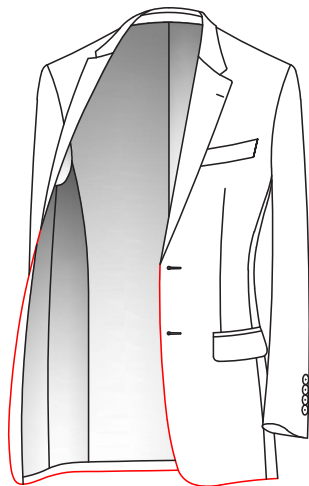

05M8 Round Bottom
Half Lining

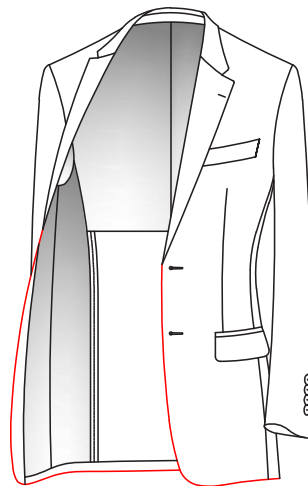

05V3 Round Bottom
No Lining

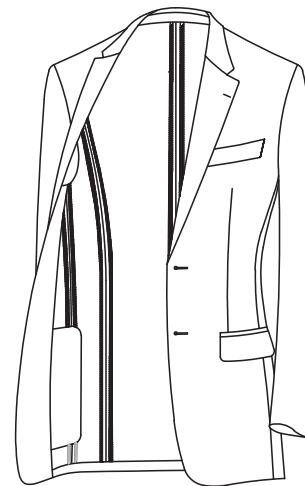

05C5 Straight Bottom
Full Lining

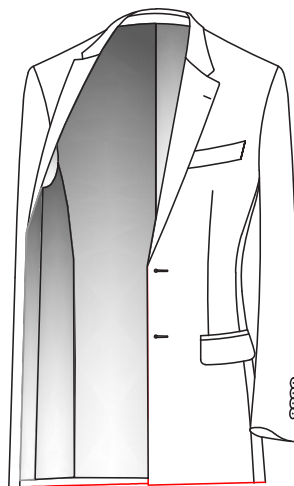

05M4 Straight Bottom
Half Lining

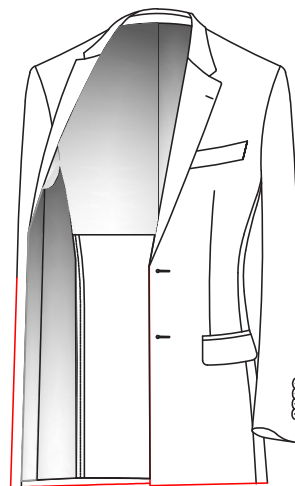

PANT

3020

Plain Front

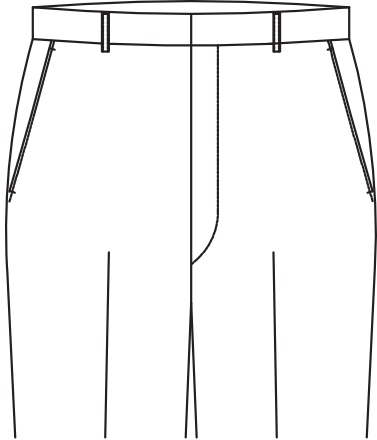

3021

Single Pleat Forward Sideseam

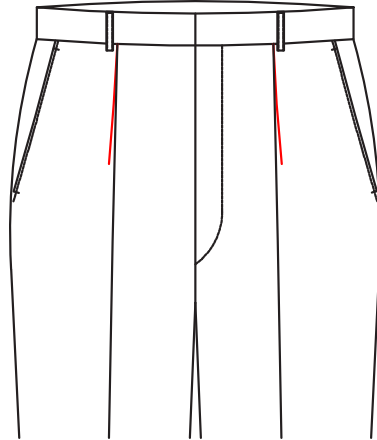

302P

Single Box Pleat

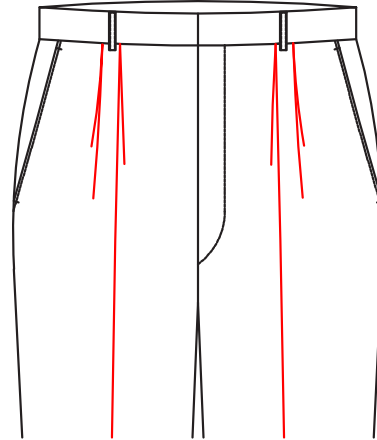

3027

Single Opposite Pleat

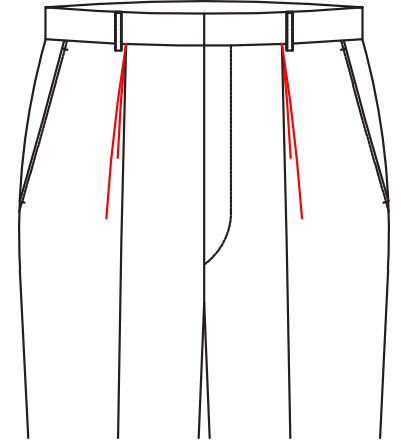

3023

Double Pleats Forward Sideseam

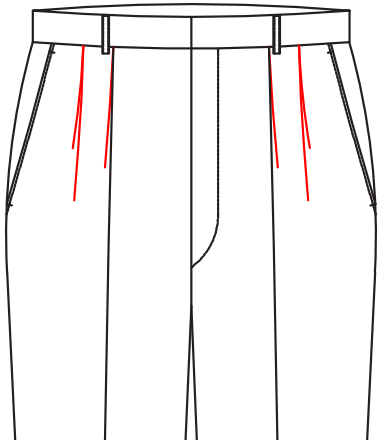

3024

Double Pleat Forward Fly

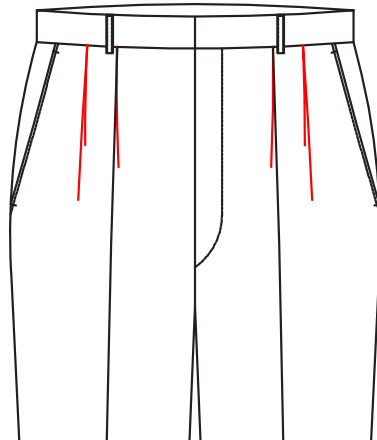

3100

Slant Pocket

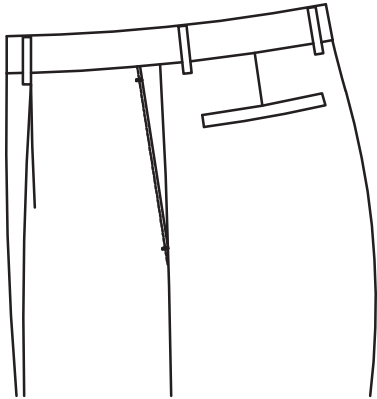

3130

Sideseam Pocket

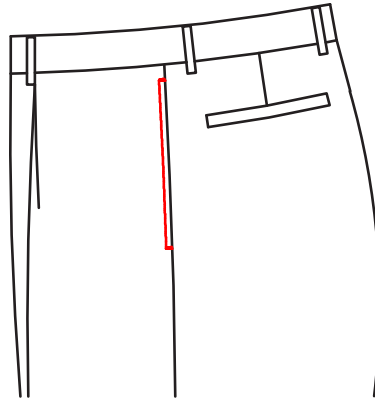

3134

Diamond Jeans Pocket

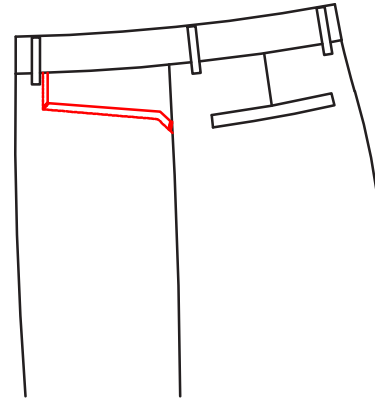

3530

Right Coin Pocket

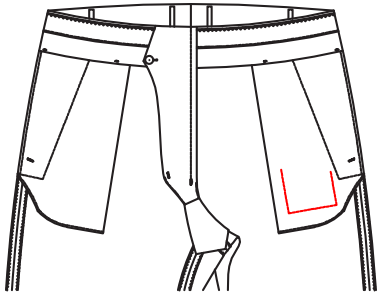

3531

Left Coin Pocket

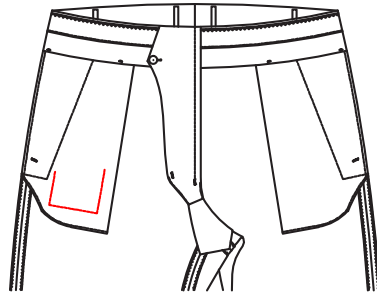

3532

Left & Right Coin Pocket

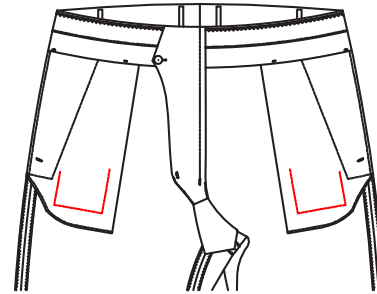

3533

No Coin Pocket

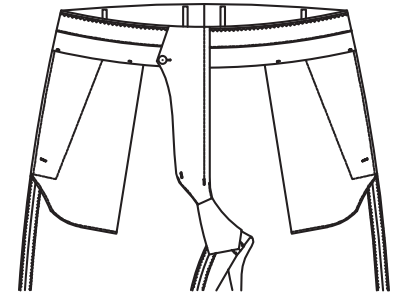

3170

Left Watch Pocket



3171

Left Besom Watch Pocket



3178

Left Double Besom Watch Pocket

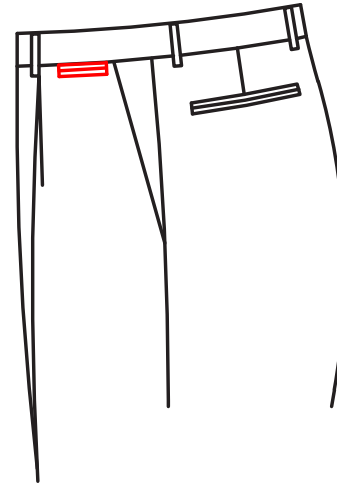

3174

Left watch Pocket w/Diamond Flap

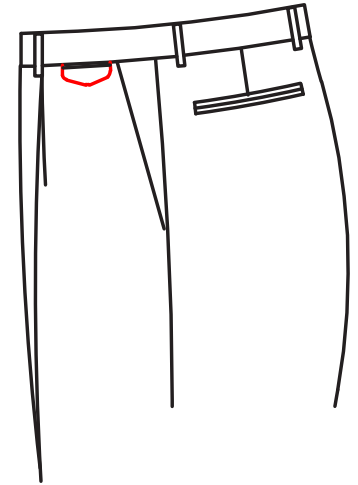

3600

Plain Bottom

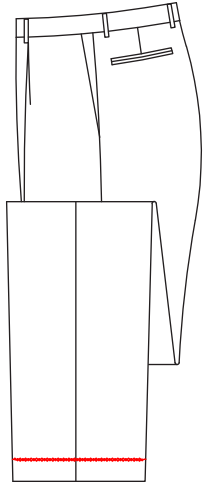

3602

1.25" (3.2cm) Cuff

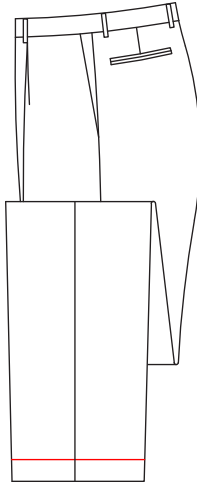

3603

1.5" (3.8cm) Cuff

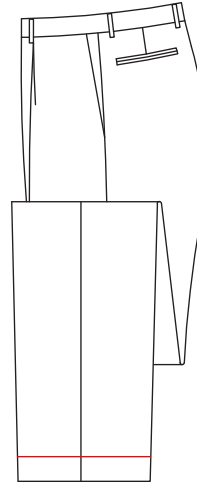

3604

1.75" (4.4cm) Cuff

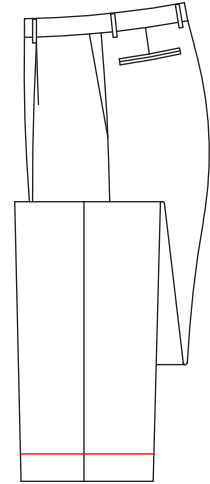

3605

2.0" (5.1cm) Cuff

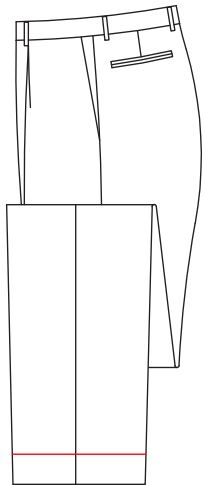

3312

narrow (0.15cm) Pick Stitch

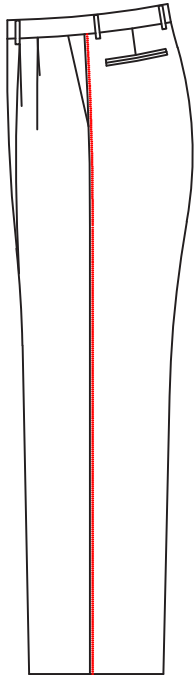

3326

wide (0.6cm) Pick Stitch

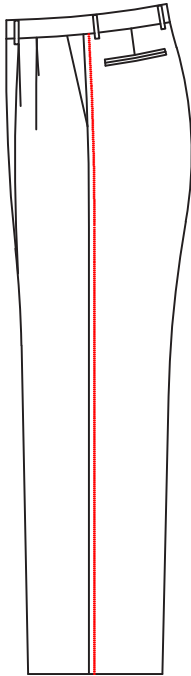

3313

0.75" (2.0cm) Satin Stripe

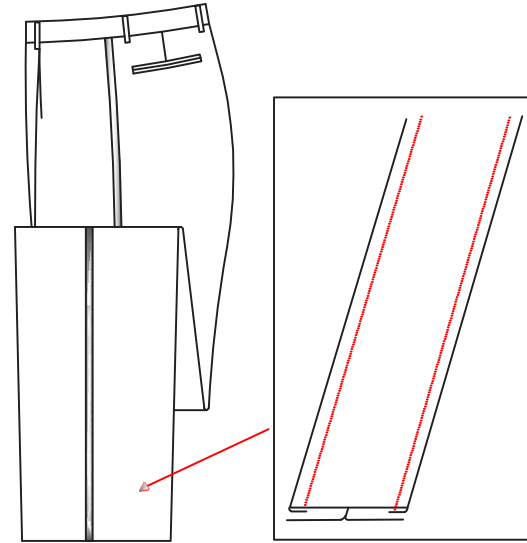

3501

Front Lining

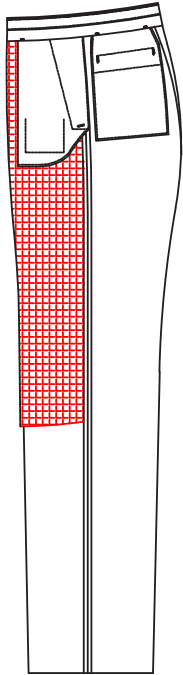

3505

Full Lining

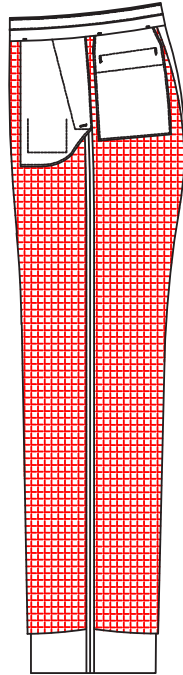

3330

Belt Loops

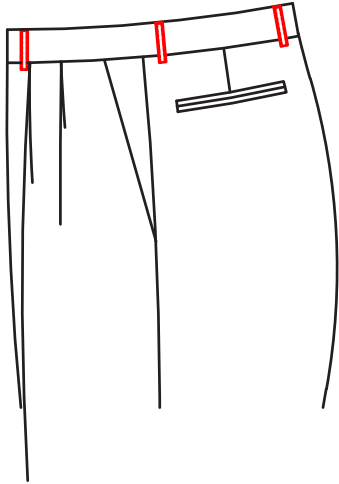

3329

No Belt Loops



33T1

Side Adjustment Buckles



VEST

4000

Standard V Shape

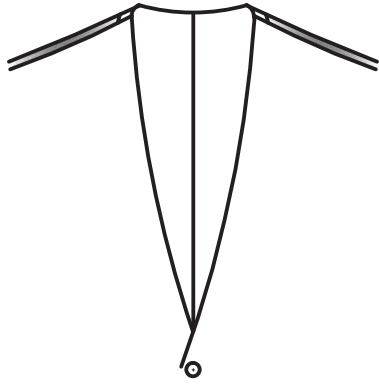

4001

U Shape

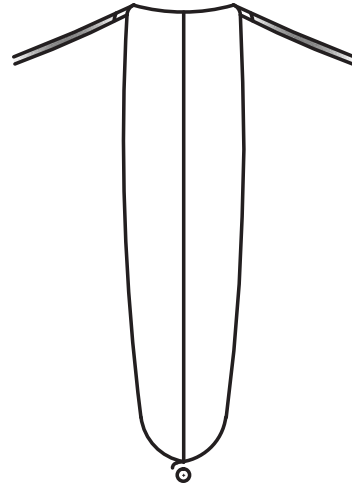

4003

Shawl Lapel

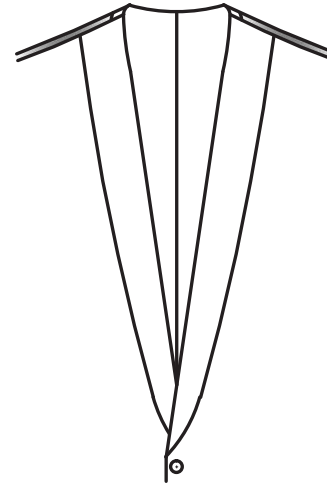

4004

Notch Lapel

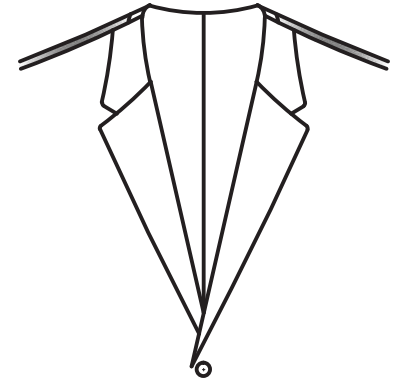

4006

Peak Lapel

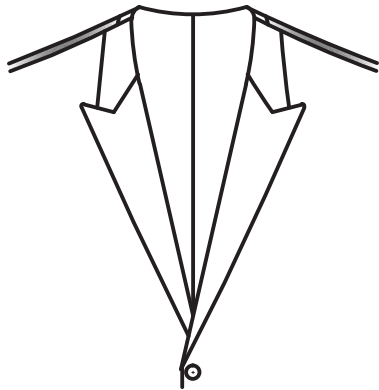

4300

Welt Pockets

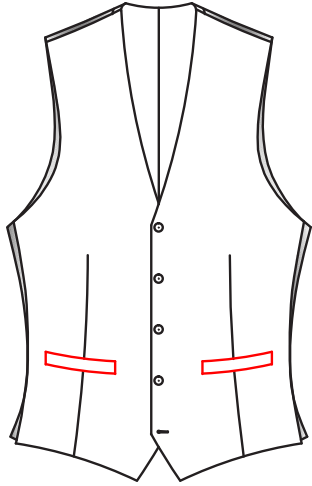

4301

Double Besom Pockets

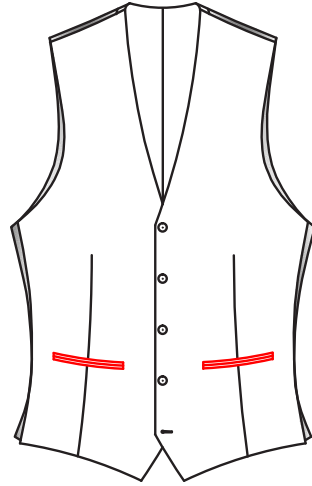

4302

Double Besom w/ Flap Pockets

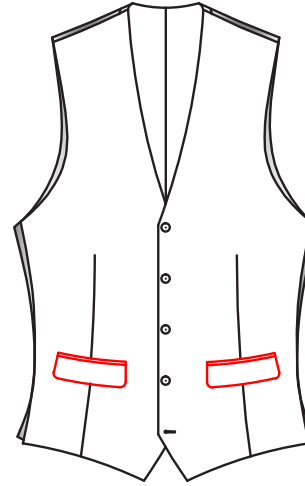

41A5

4 Welt Pockets

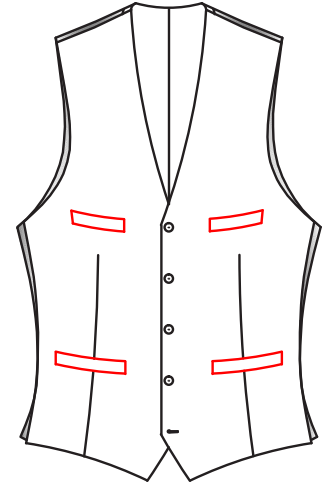

401C

Single Breasted 3 Buttons

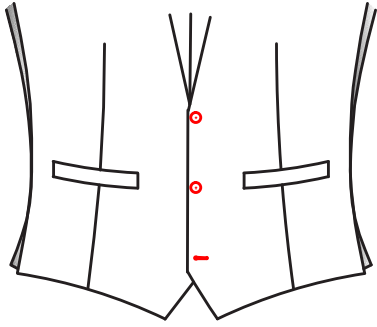

401D

Single Breasted 4 Buttons

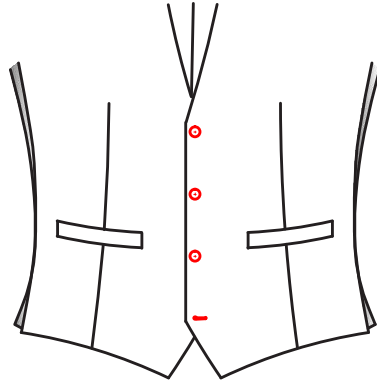

401G

Single Breasted 5 Buttons

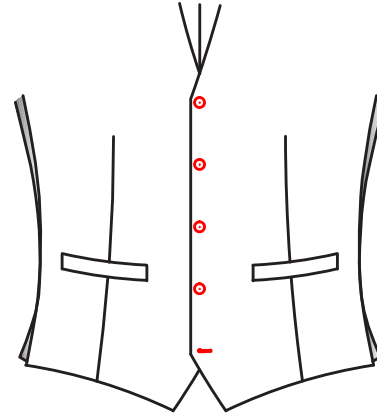

401M

Single Breasted 4 Buttons
w/ 2 Fasten

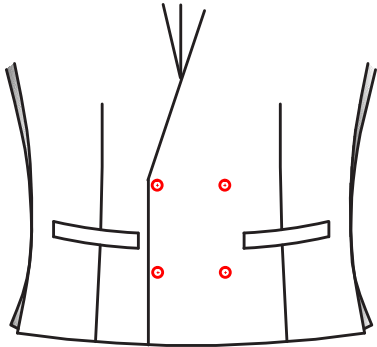

401K

Single Breasted 6 Buttons
w/ 3 Fasten

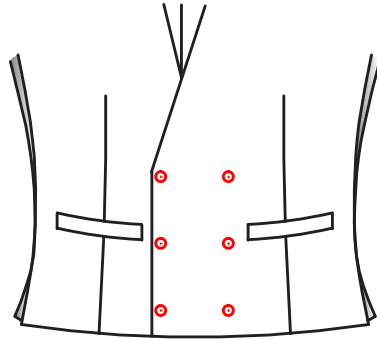

401J

Pointed Bottom

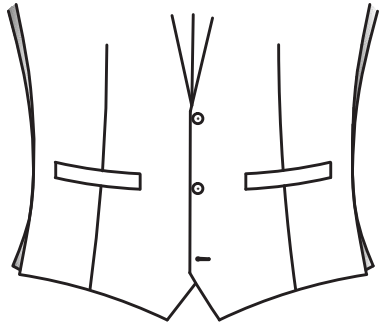

401Z

Square Bottom

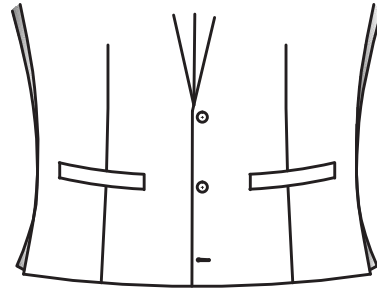

4571

narrow (0.15cm) Pick Stitch

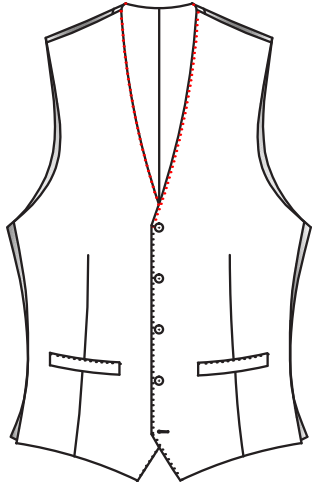

4576

wide (0.6cm) Pick Stitch

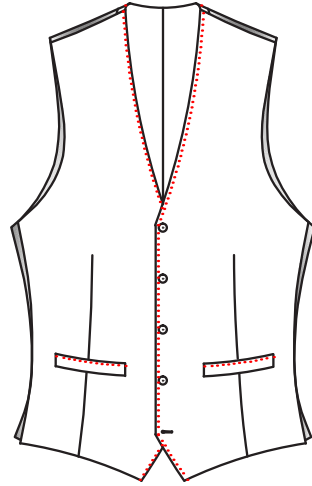

Strap w/ Lining Back

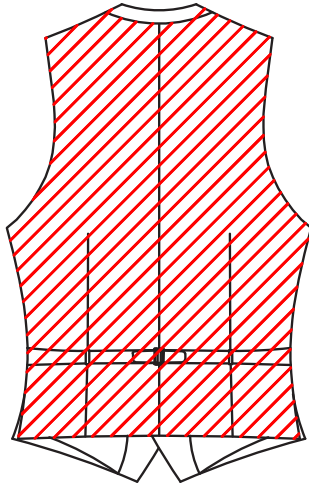

No Strap w/ Lining Back

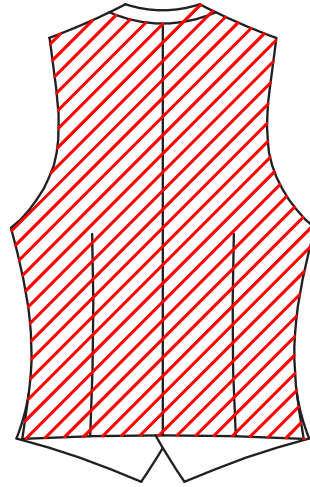

Strap w/ Fabric Back

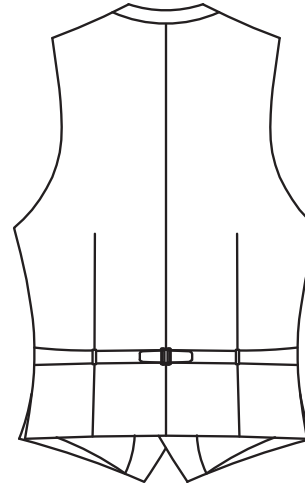

No Strap w/ Fabric Back

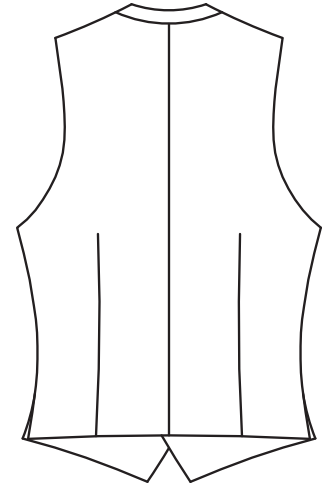

SHIRT

518B

Left and Right Plain



5101

Left Placket

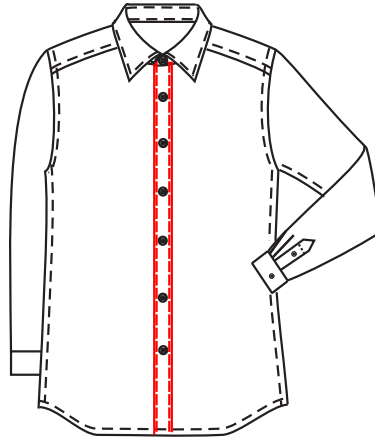

520Q

Left & Right Placket

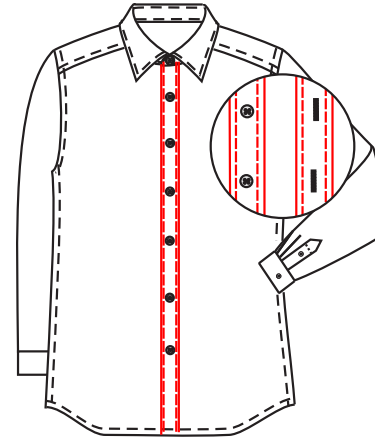

5103

Hidden Button

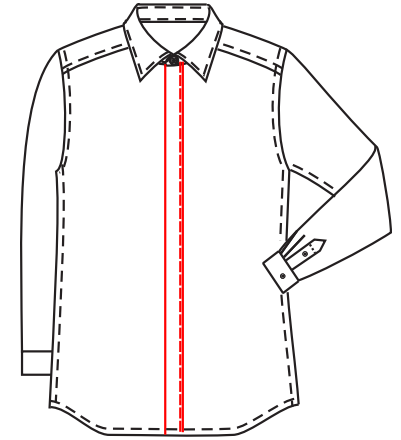

520S

Tuxedo Front

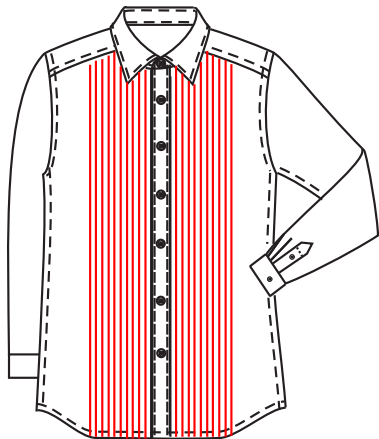

5140

No Pleats or Darts

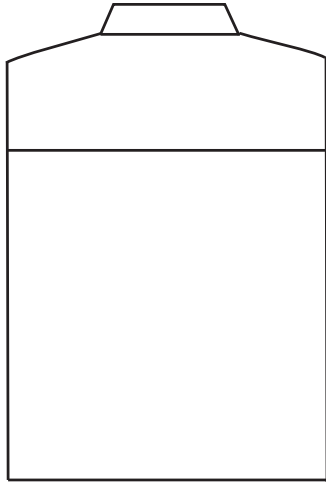

5141

Side Pleats

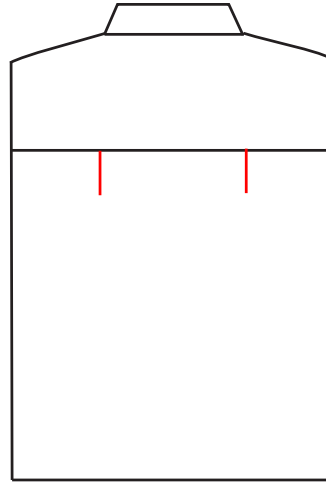

5143

Box Pleats

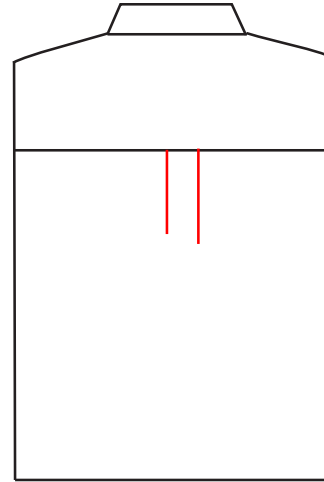

5AM3

Cut Collar

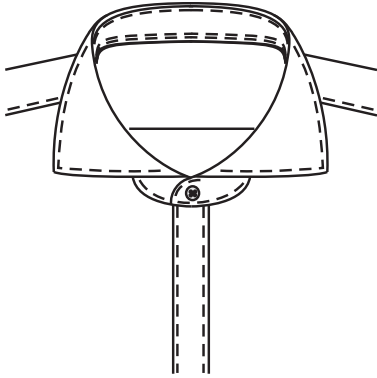

5AL9

Cut Away Collar

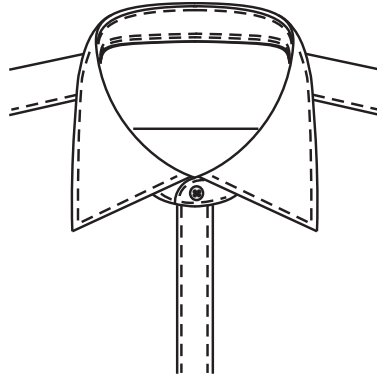

5AL5

Square Collar

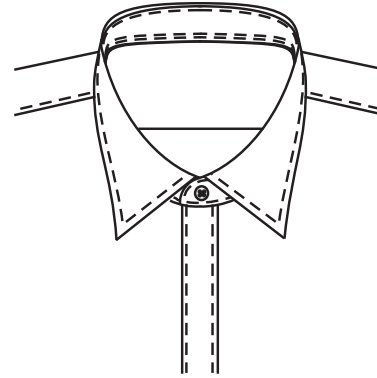

5AK9

Pointed Collar

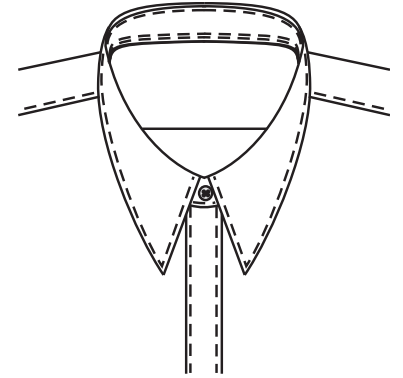

5260

Tuxedo Collar

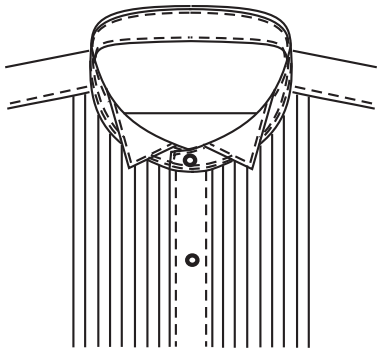

5290

Collar Point w/Button

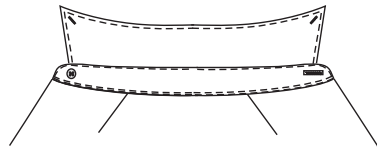

5291

Collar Point w/ Hidden Button

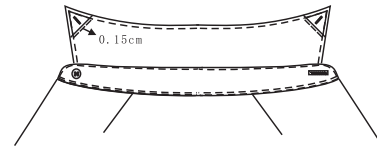

5280

Fixed Collar Stay

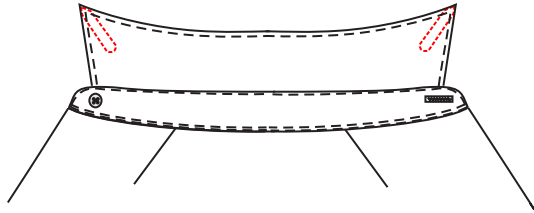

5281

Removable Collar Stay

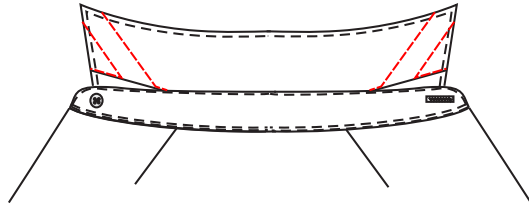

5282

No Collar Stay

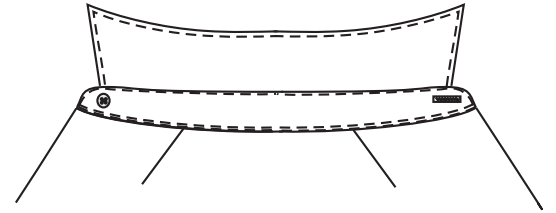

5312

Hexagon Pocket

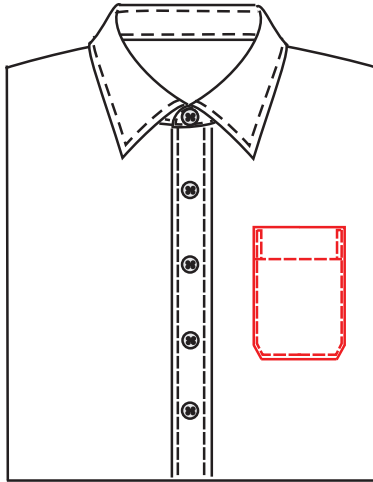

5323

Rounded Pocket

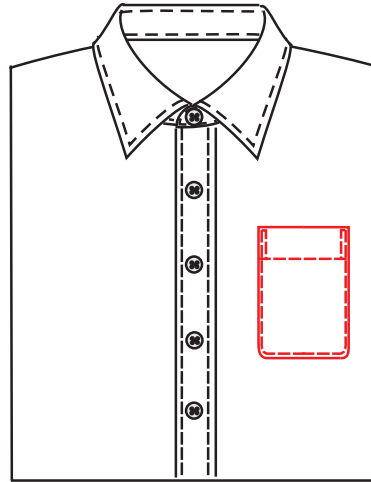

5340

Square Pocket

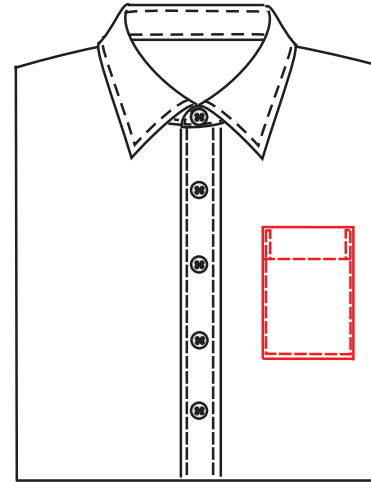

5300

Triangle Pocket

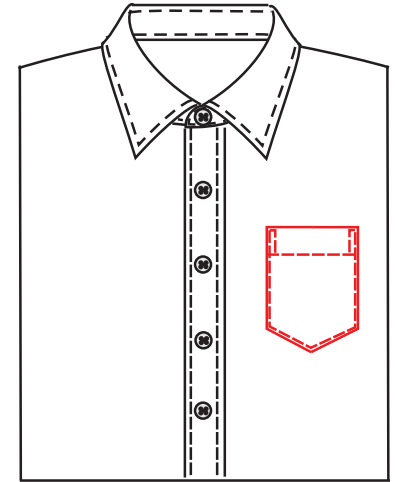

5360

No Pocket

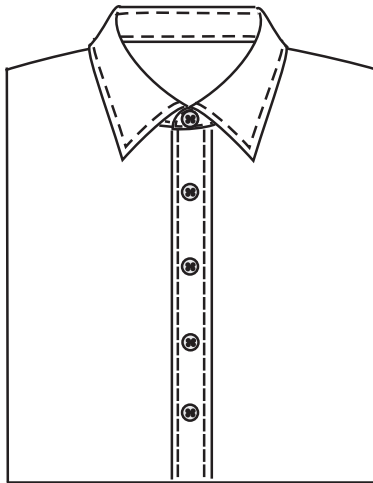

5120

Rounded Bottom

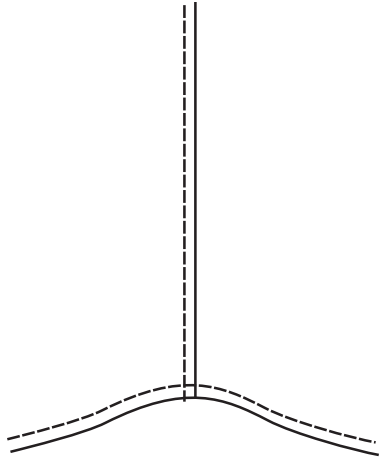

5130

Square Bottom

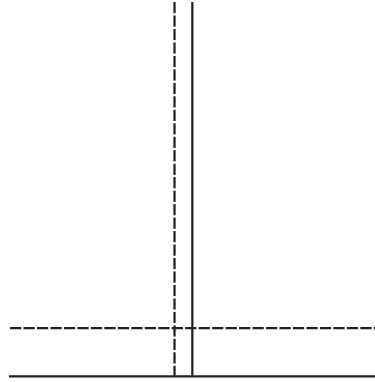

5131

Straight Side Vents Bottom

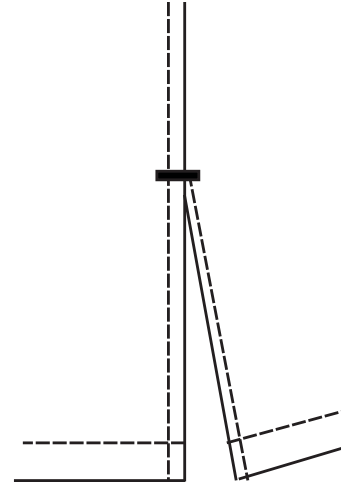

5430 Hexagon
1 Button 1 Buttonhole

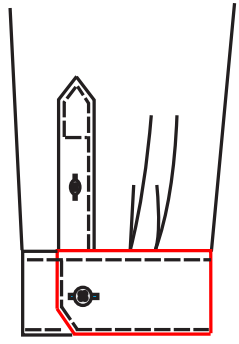

5410 Round
1 Button 1 Buttonhole

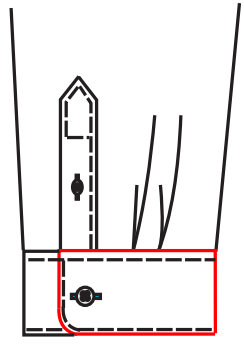

5400 Square
1 Button 1 Buttonhole

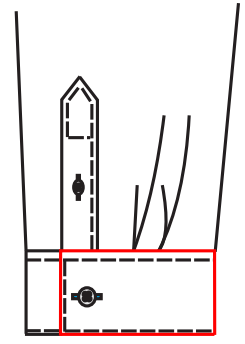

5432 Hexagon
2 Button 2 Buttonhole

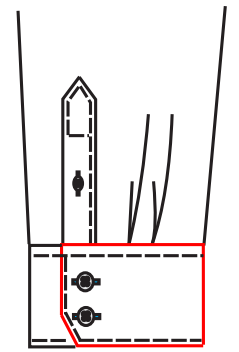

5412 Round
2 Button 2 Buttonhole

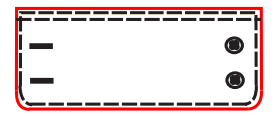
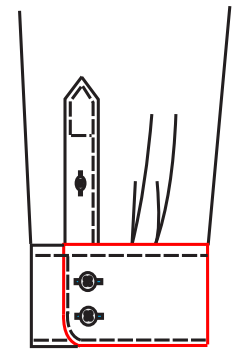

5402 Square
2 Button 2 Buttonhole

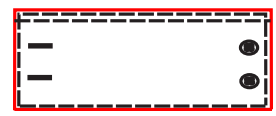
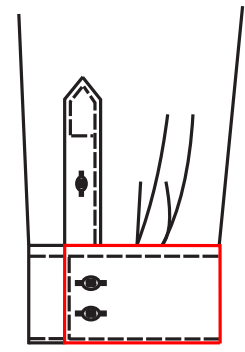

5452

Hexagon
French Cuff

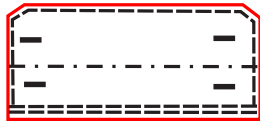
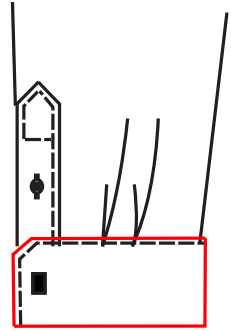

5451

Round
French Cuff

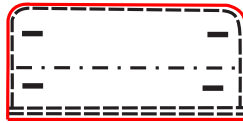
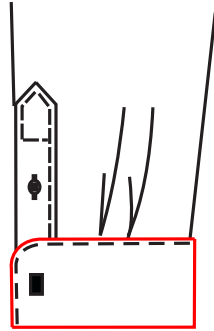

5455

Square
French Cuff

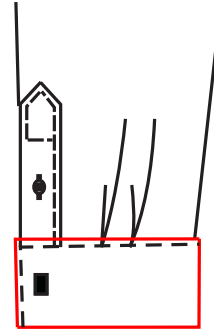

54A0

Short Sleeve Plain

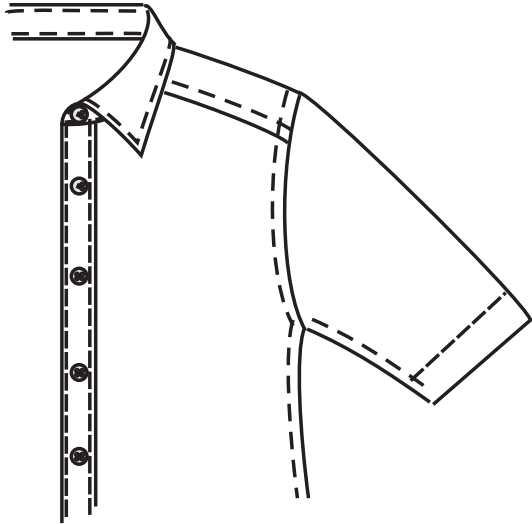

54A1

Short Sleeve Fake Hem

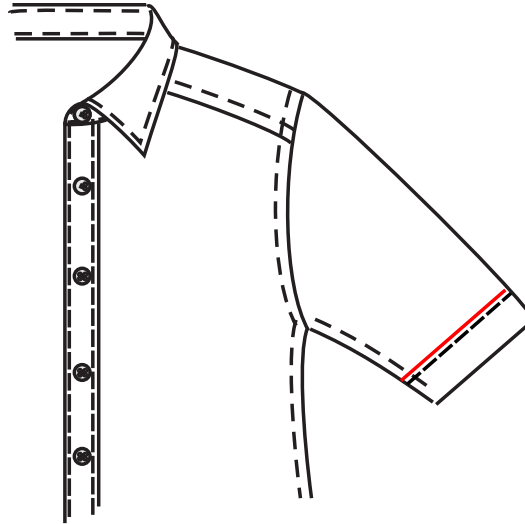

54A2

Short Sleeve Plain w/Slit

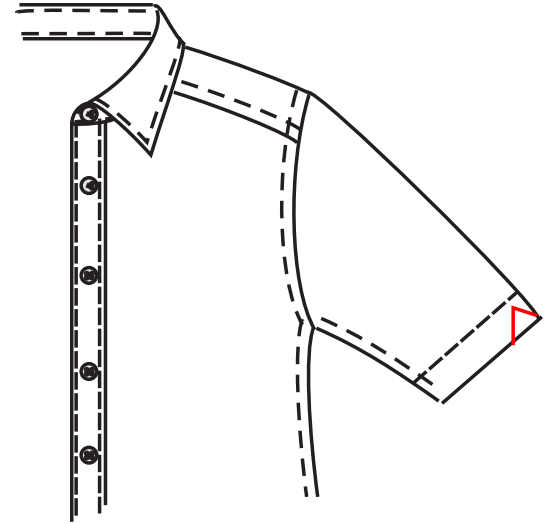

OVERCOAT

6012

Single Breasted
Two Button

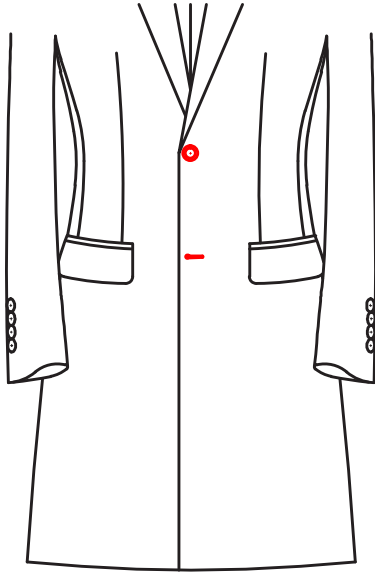

6013

Single Breasted
Three Button

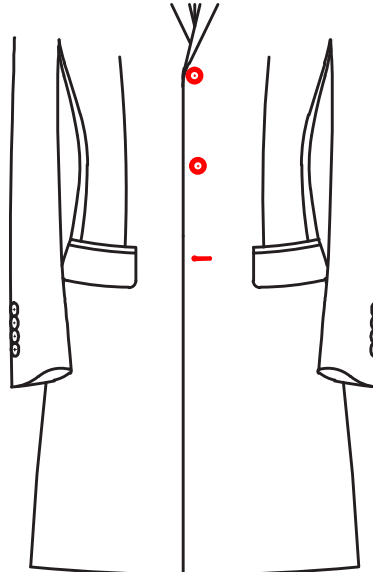

6015

Double Breasted
Four Button (Two Fasten)

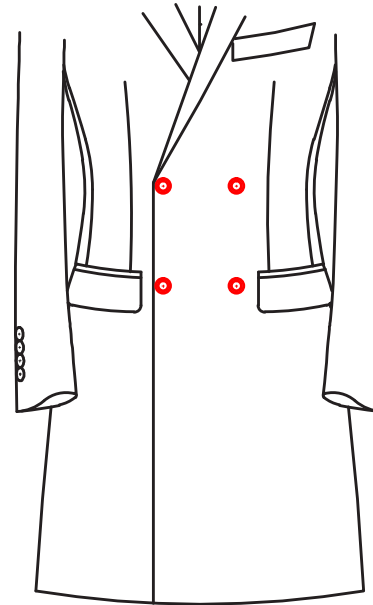

6016

Double Breasted
Six Button (Two Fasten)

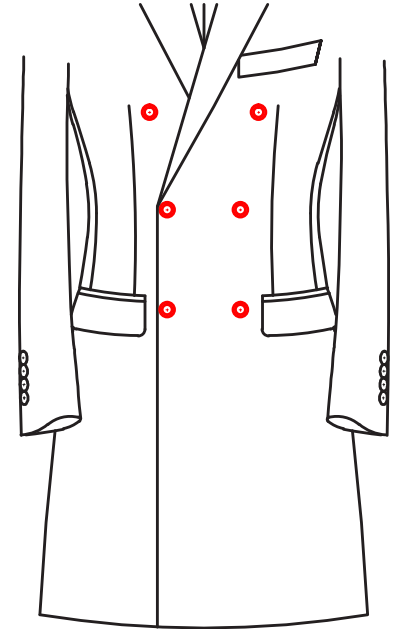

64N1

Center Vent

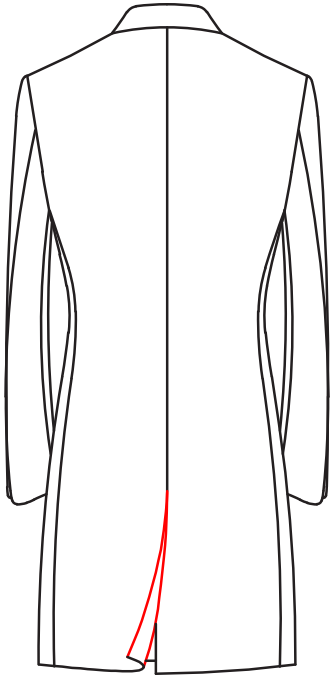

64H1

Center Vent w/ Back Belt

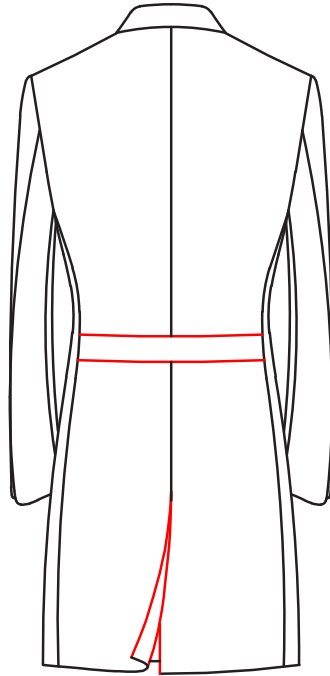

64N0

No Vent

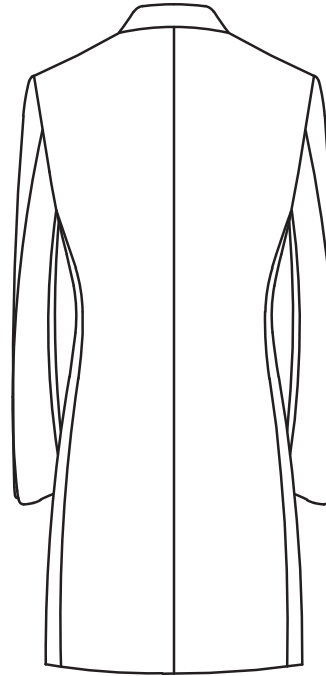

64H0

No Vent w/ Back Belt

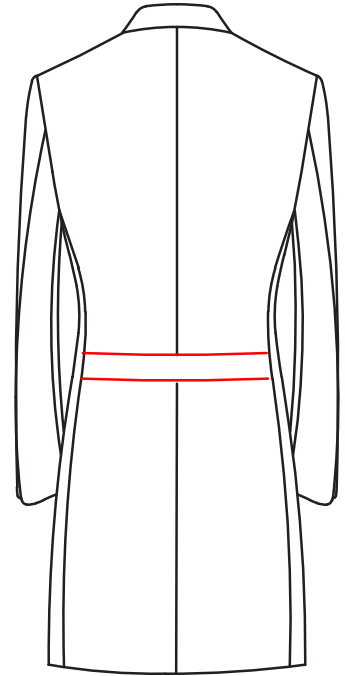

6001

Notch Lapel

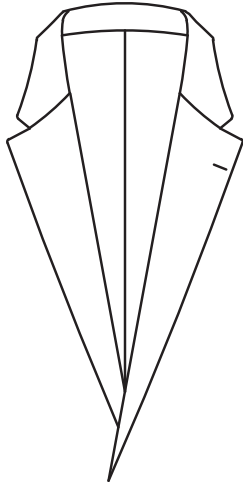

6002

Peak Lapel

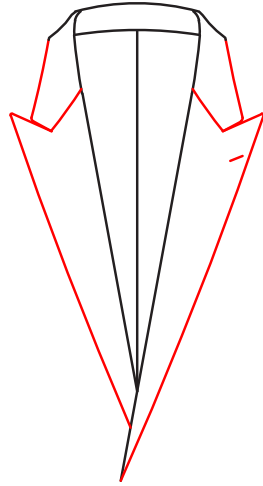

6007

Closed Collar

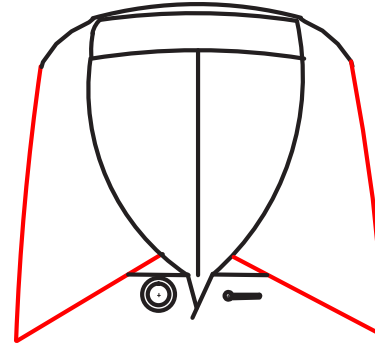

6541

Left Lapel Buttonhole

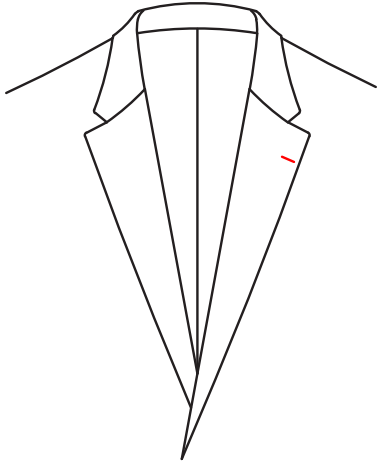

6542

Right Lapel Buttonhole

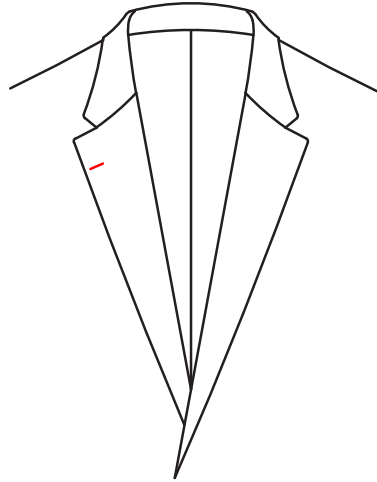

6543

Left & Right Buttonhole

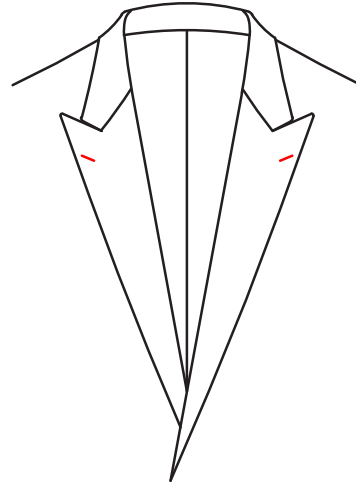

6544

No Buttonhole

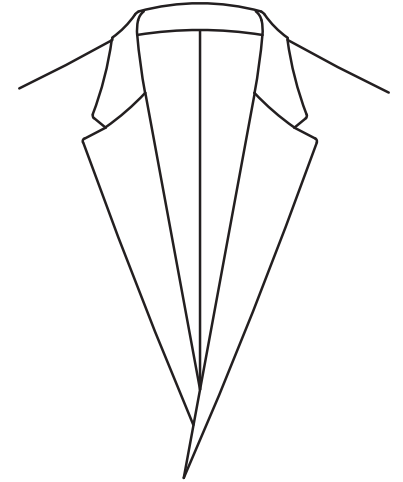

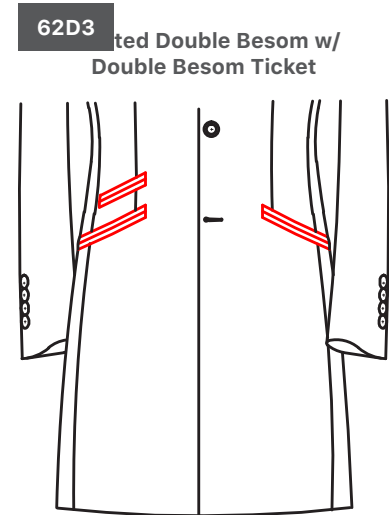
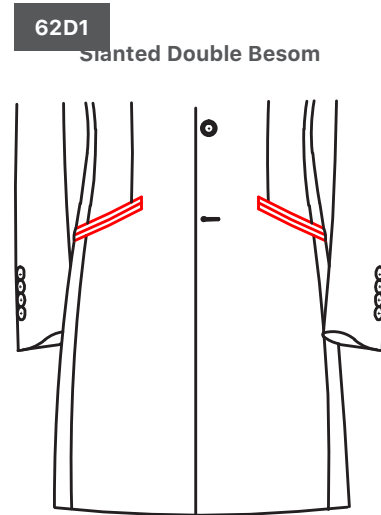
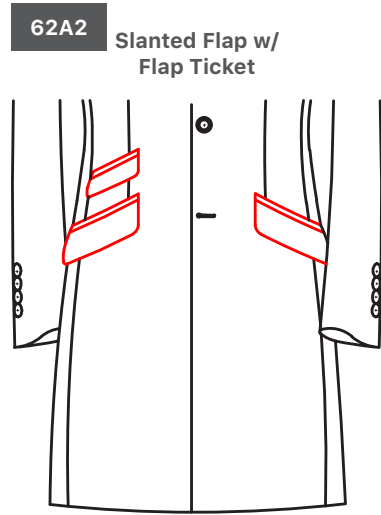
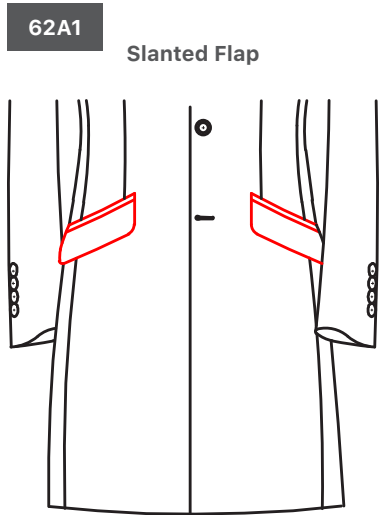
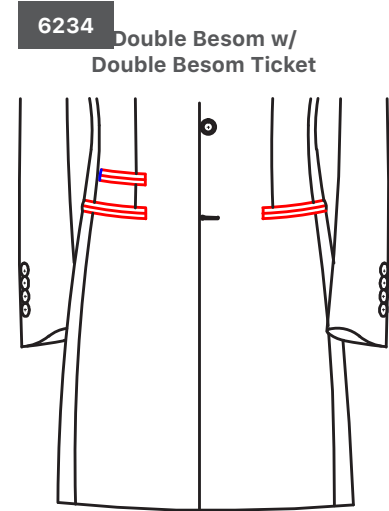
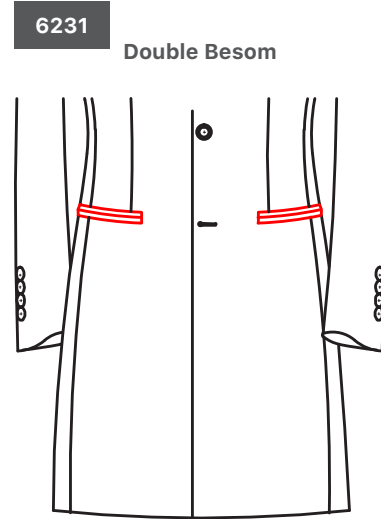
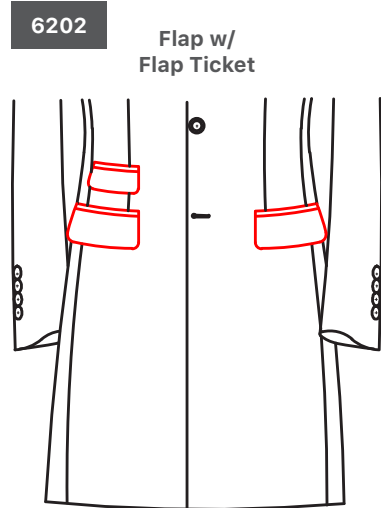
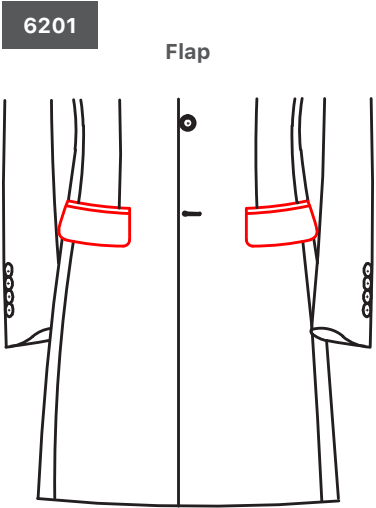

6204

Flap w/
Double Besom Ticket

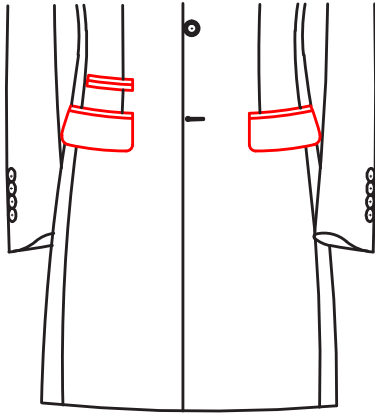

62S1

Slanted Welt

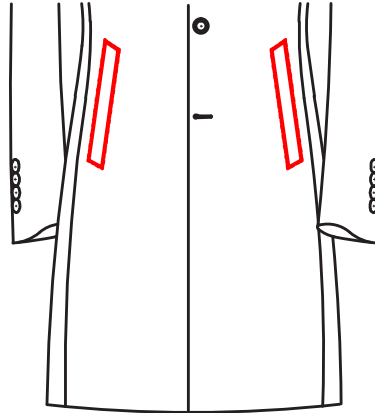

6625

Three Overlapping Buttons

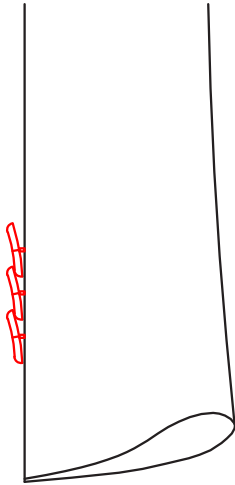

6624

Three Flat Buttons

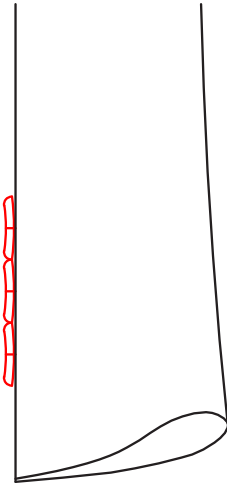

6622

Four Overlapping Buttons

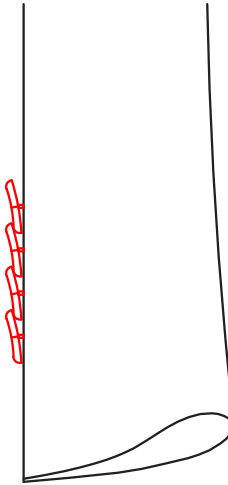

6621

Four Flat Buttons

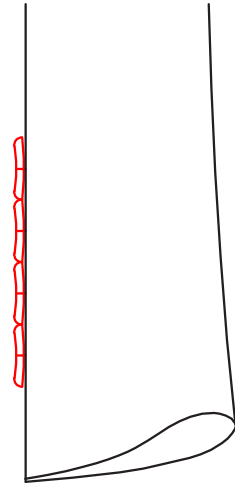

6623

One Big Button

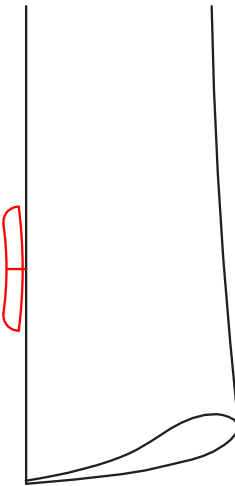

661G

No Sleeve Slit
Pointed Tab w/ Buttonhole

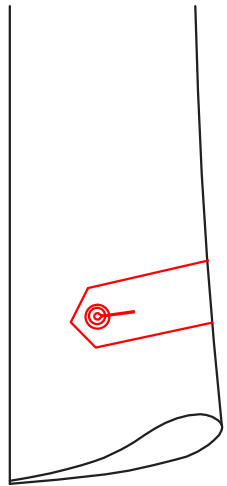

661M

No Sleeve Slit
Rounded Tab

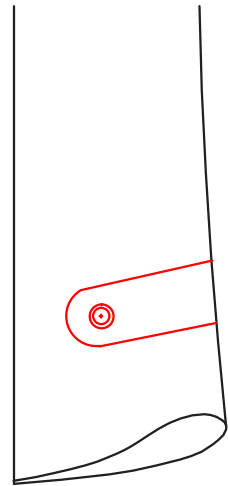

6612

Real Slit

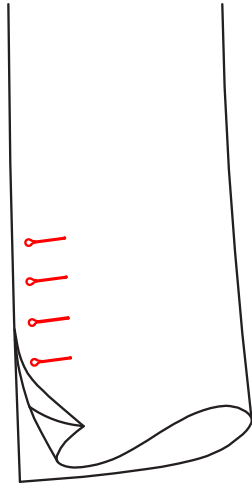

661D

Slanted Real Slit

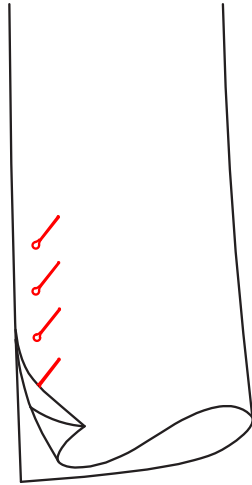

6572

narrow (0.3cm) Pick Stitch

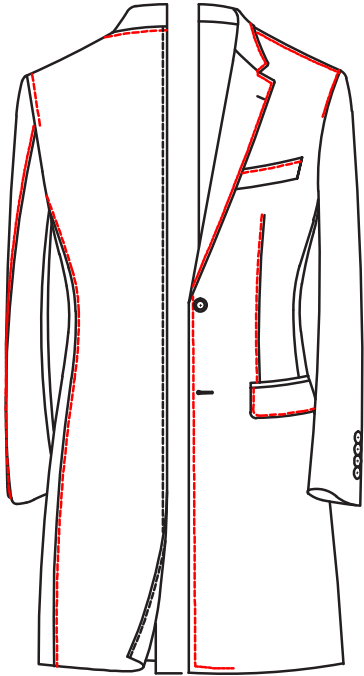

6577

wide (0.8cm) Pick Stitch

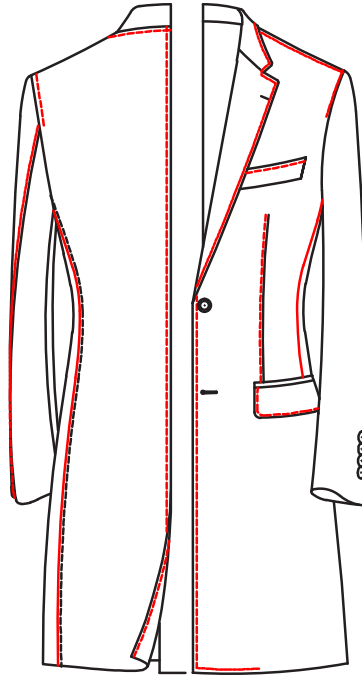

6570

No Pick Stitch

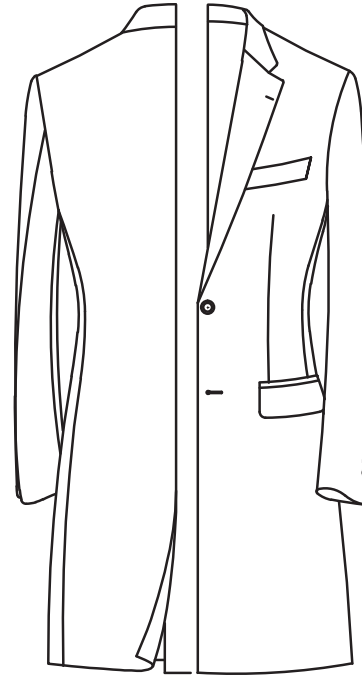

6601

Normal

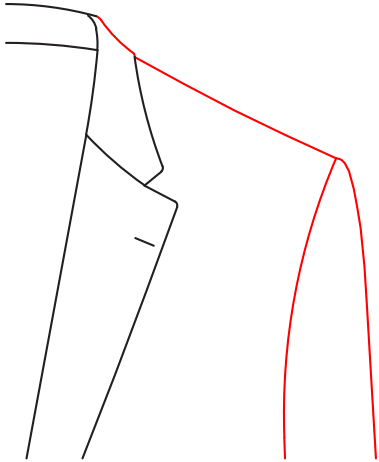

6603

Natural

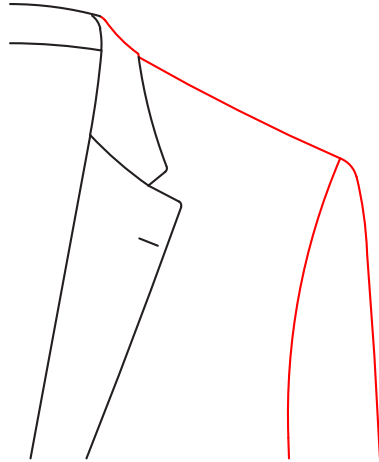

6602

High Sleevehead

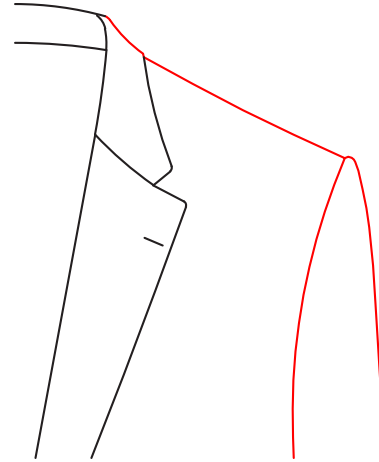

660B

Point Epaulet w/ Buttonhole

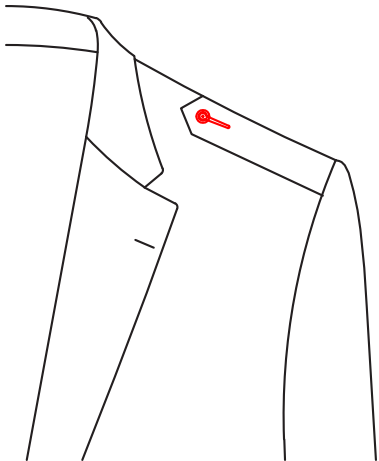

660E

Round Epaulet w/ Buttonhole

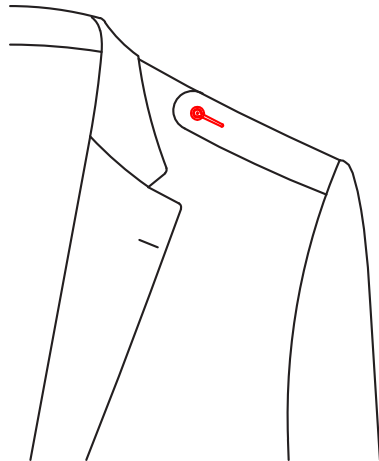

6100

No Breast Pocket



6101

Breast Pocket

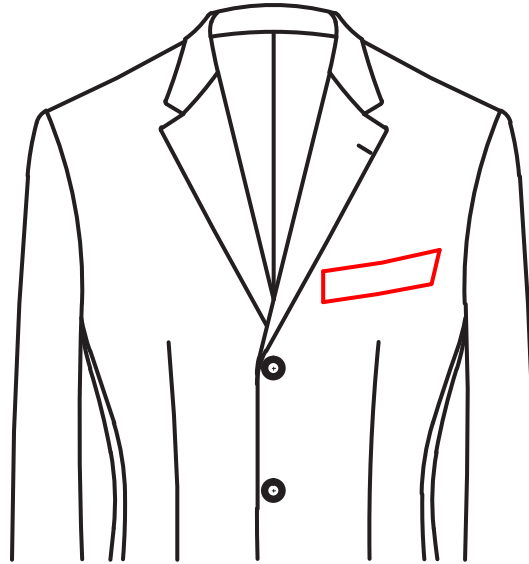

JEANS

Normal Belt Loops



Wide Belt Loops



Double Belt Loops



Double X Belt Loops



No Belt Loops



Round Pocket



Slant Pocket



Square Pocket



No Coin Pocket



Single Welt Coin Pocket



Double Welt Coin Pocket



Diagonal Coin Pocket



Square Coin Pocket



Round Pocket



Square Pocket



Diagonal Pocket



02



03



04



05



06



08



10



12



No Fade



Slight Fade



Regular Fade



Strong Fade



MONOGRAM

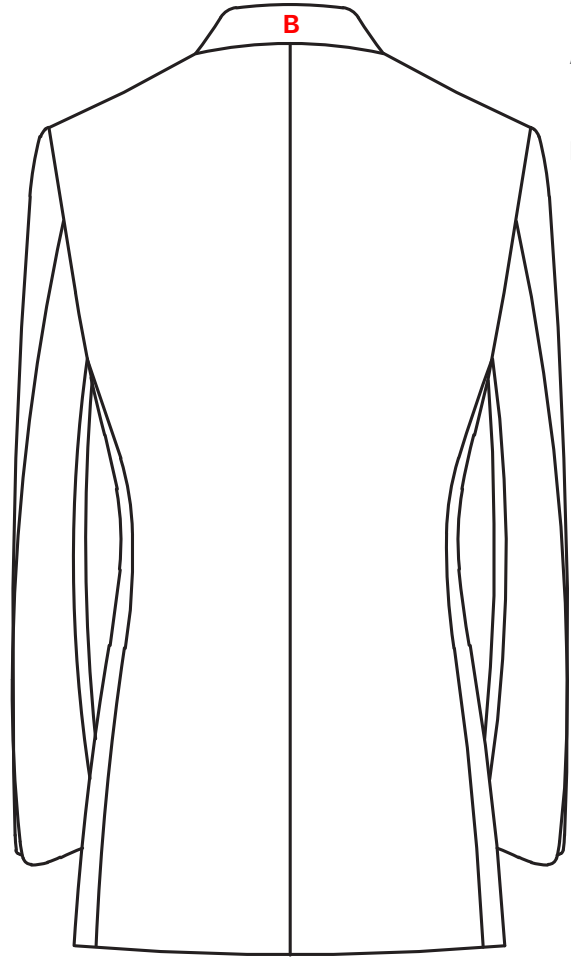
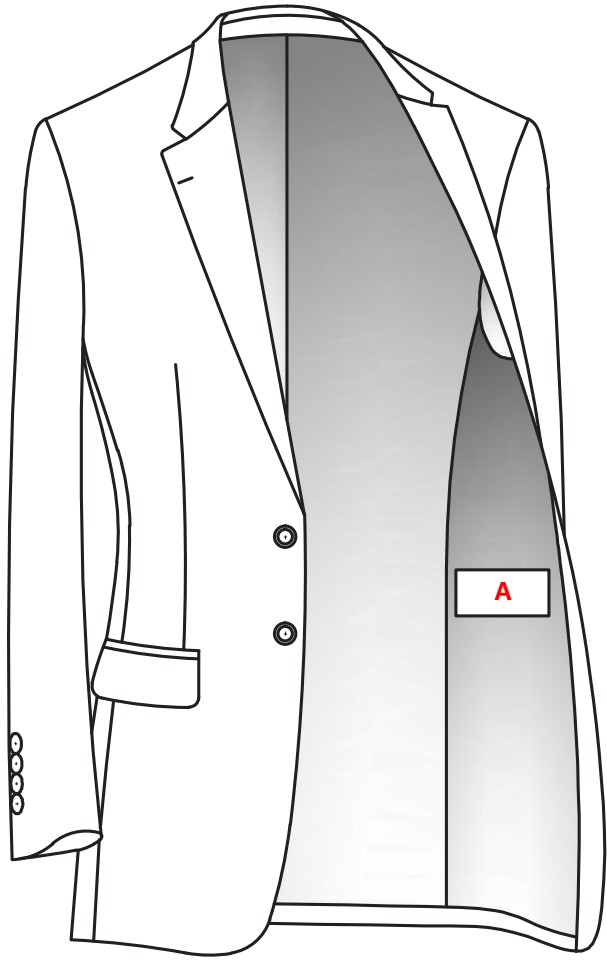

A Name Label

B Collar Felt

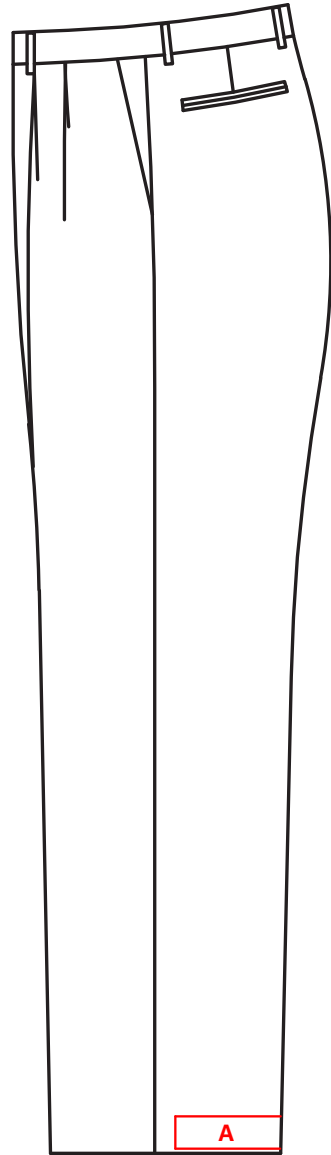

A Left & Right Heel Guard

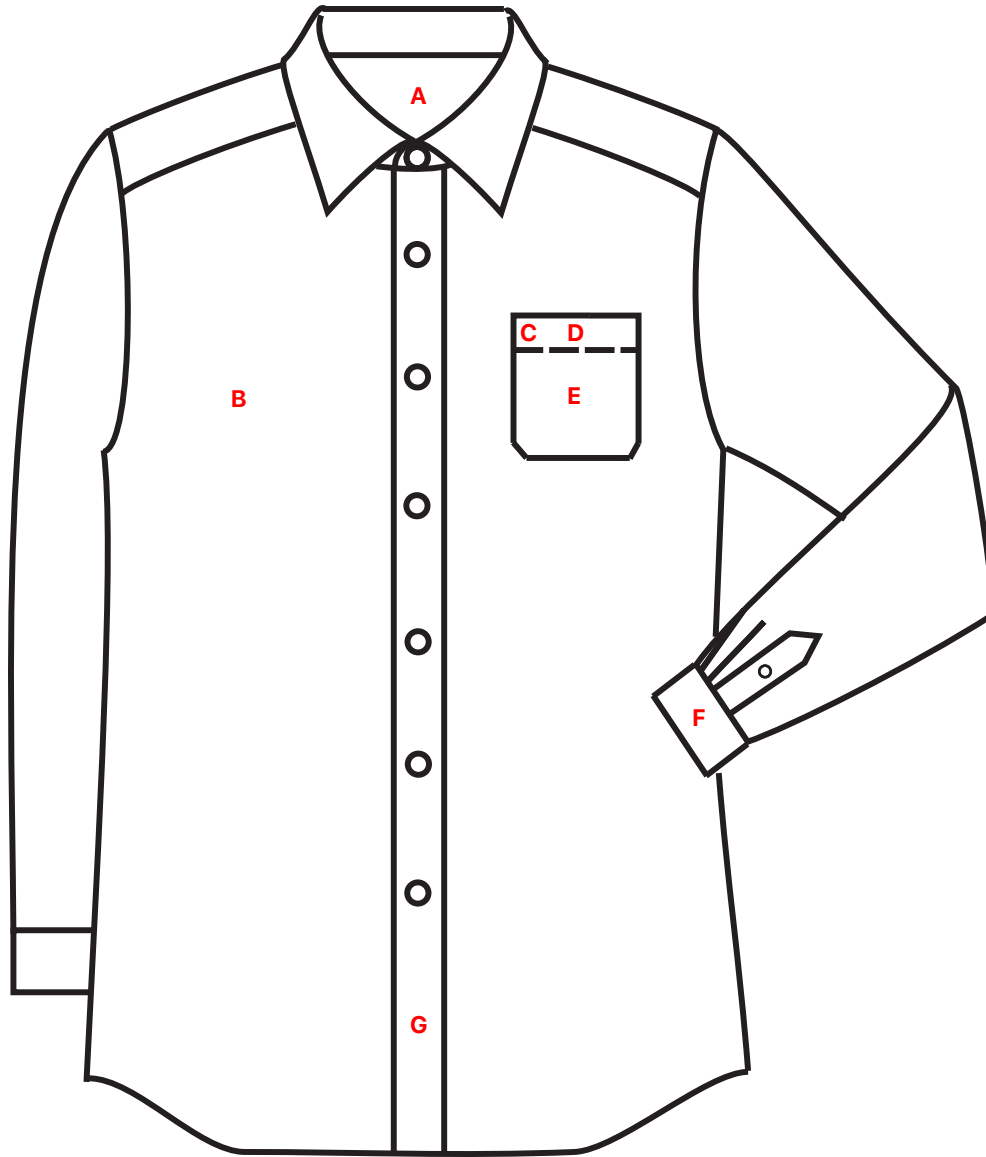

A Inside Yoke

B Right Chest

C Pocket Top (Right)

D Pocket Top (Center)

E Pocket Center

F Left Cuff

G Bottom Of Shirt

- 01 Calligraphy *AaBbCcDdEeFfGgHhIiJjKkLlMmNnOoPpQqRrSsTtUuVvWwXxYyZz*
- 02 Times Roman AaBbCcDdEeFfGgHhIiJjKkLlMmNnOoPpQqRrSsTtUuVvWwXxYyZz
- 03 Block AaBbCcDdEeFfGgHhIiJjKkLlMmNnOoPpQqRrSsTtUuVvWwXxYyZz
- 04 Script *AaBbCcDdEeFfGgHhIiJjKkLlMmNnOoPpQqRrSsTtUuVvWwXxYyZz*
- 05 Bradley Light AaBbCcDdEeFfGgHhIiJjKkLlMmNnOoPpQqRrSsTtUuVvWwXxYyZz
- 06 Bank Gothic AaBbCcDdEeFfGgHhIiJjKkLlMmNnOoPpQqRrSsTtUuVvWwXxYyZz
- 07 Book Script *AaBbCcDdEeFfGgHhIiJjKkLlMmNnOoPpQqRrSsTtUuVvWwXxYyZz*
- 08 Old English *AaBbCcDdEeFfGgHhIiJjKkLlMmNnOoPpQqRrSsTtUuVvWwXxYyZz*
- 09 Gradl AaBbCcDdEeFfGgHhIiJjKkLlMmNnOoPpQqRrSsTtUuVvWwXxYyZz
- 10 Iowan AaBbCcDdEeFfGgHhIiJjKkLlMmNnOoPpQqRrSsTtUuVvWwXxYyZz
- 11 Cochin AaBbCcDdEeFfGgHhIiJjKkLlMmNnOoPpQqRrSsTtUuVvWwXxYyZz
- 12 Bradley Bold AaBbCcDdEeFfGgHhIiJjKkLlMmNnOoPpQqRrSsTtUuVvWwXxYyZz